



---

## LOW POWER STEREO AUDIO DAC WITH HEADPHONE / SPEAKER AMPLIFIER

---

### FEATURES

- Low Power High Quality Audio DAC
- Stereo Audio DAC Support Rates up to 48 ksps
- High Quality 97-dBA Stereo Audio Playback Performance
- Low Power: 11-mW Stereo Audio Playback at 48 ksps
- On-Chip 325-mW, 8- $\Omega$  Speaker Driver
- Stereo Headphone Amplifier With Capless Output Option
- Integrated PLL for Flexible Audio Clock Generation
- Programmable Digital Audio Bass/Treble/EQ/De-Emphasis
- Microphone and AUX Inputs Available for Analog Sidetone Mixing
- Microphone Bias and Pre-Amp
- SPI™ and I<sup>2</sup>S™ Serial Interfaces
- Full Power-Down Control
- 32-Pin 5×5 mm QFN Package

### APPLICATIONS

- MP3 Players
- Digital Still Cameras
- Digital Video Camcorders

### DESCRIPTION

The TLV320DAC26 is a high-performance audio DAC with 16/20/24/32-bit 97-dBA stereo playback. The audio output drivers on the 'DAC26 are highly flexible, having software-programmable low or high-power drive modes to optimize system power dissipation. The outputs can be configured to supply up to 330 mW into a bridge terminated 8- $\Omega$  load, can support stereo 16- $\Omega$  headphone amplifiers in ac-coupled or capless output configurations, and can supply a stereo line-level output

A programmable digital audio effects processor enables bass, treble, midrange, or equalization playback processing. The digital audio data format is programmable to work with popular audio standard protocols (I<sup>2</sup>S, DSP, Left/Right Justified) in master or slave mode, and also includes an on-chip programmable PLL for flexible clock generation capability. Highly configurable software power control is provided, enabling stereo audio playback at 48 ksps at 11 mW with a 3.3-V analog supply level.

The 'DAC26 is available in a 32 lead QFN.



Please be aware that an important notice concerning availability, standard warranty, and use in critical applications of Texas Instruments semiconductor products and disclaimers thereto appears at the end of this data sheet.

SPI is a trademark of Motorola.

I<sup>2</sup>S is a trademark of Phillips Electronics.



This integrated circuit can be damaged by ESD. Texas Instruments recommends that all integrated circuits be handled with appropriate precautions. Failure to observe proper handling and installation procedures can cause damage.

ESD damage can range from subtle performance degradation to complete device failure. Precision integrated circuits may be more susceptible to damage because very small parametric changes could cause the device not to meet its published specifications.

**PACKAGE/ORDERING INFORMATION**

PRODUCT	PACKAGE	PACKAGE DESIGNATOR	OPERATING TEMPERATURE RANGE	ORDERING NUMBER	TRANSPORT MEDIA, QUANTITY
TLV320DAC26	QFN-32	RHB	-40°C to 85°C	TLV320DAC26IRHB	Tubes, 74
				TLV320DAC26IRHBR	Tape and Reel, 3000

**PIN ASSIGNMENTS**

(TOP VIEW)

QFN

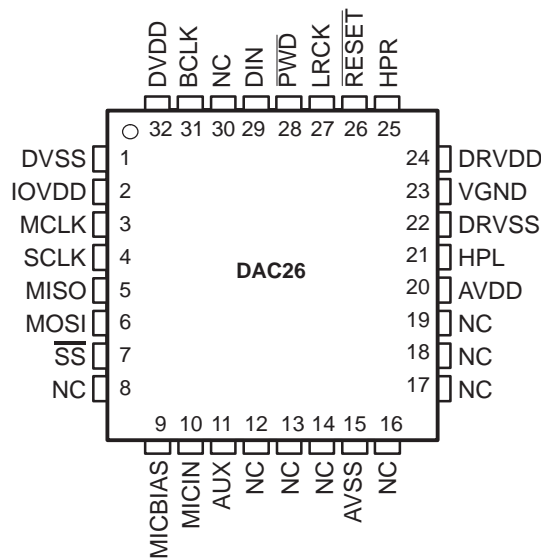

**Terminal Functions**

QFN PIN	NAME	DESCRIPTION	QFN PIN	NAME	DESCRIPTION
1	DVSS	Digital core and IO ground	17	NC	No connect
2	IOVDD	IO supply	18	NC	No connect
3	MCLK	Master clock	19	NC	No connect
4	SCLK	SPI serial clock input	20	AVDD	Analog power supply
5	MISO	SPI serial data output	21	HPL	Left channel audio output
6	MOSI	SPI serial data input	22	DRVSS	Speaker ground
7	SS	SPI slave select input	23	VGND	Virtual ground for audio output
8	NC	No connect	24	DRVDD	Speaker /PLL supply
9	MICBIAS	Microphone bias voltage	25	HPR	Right channel audio output
10	MICIN	Microphone input	26	RESET	Device reset
11	AUX	Auxiliary input	27	LRCK	Audio DAC word-clock
12	NC	No connect	28	PWD	Hardware powerdown
13	NC	No connect	29	DIN	Audio data input
14	NC	No connect	30	NC	No connect
15	AVSS	Analog ground	31	BCLK	Audio bit-clock
16	NC	No connect	32	DVDD	Digital core supply

## ABSOLUTE MAXIMUM RATINGS

over operating free-air temperature range unless otherwise noted<sup>(1)(2)</sup>

		UNITS
AVDD to AVSS		–0.3 V to 3.9 V
DRVDD to DRVSS		–0.3 V to 3.9 V
IOVDD to DVSS		–0.3 V to 3.9 V
DVDD to DVSS		–0.3 V to 2.5 V
AVDD to DRVDD		–0.1 V to 0.1 V
AVSS to DRVSS to DVSS		–0.1 V to 0.1 V
Analog inputs to AVSS		–0.3 V to AVDD + 0.3 V
Digital input voltage to DVSS		–0.3 V to IOVDD + 0.3 V
Operating temperature range		–40°C to 85°C
Storage temperature range		–65°C to 105°C
Junction temperature (T <sub>J</sub> Max)		105°C
QFN package	Power dissipation	(T <sub>J</sub> Max – T <sub>A</sub> )/θ <sub>JA</sub>
	θ <sub>JA</sub> Thermal impedance	123°C/W
Lead temperature	Soldering vapor phase (60 sec)	215°C
	Infrared (15 sec)	220°C

(1) Stresses beyond those listed under “absolute maximum ratings” may cause permanent damage to the device. These are stress ratings only, and functional operation of the device at these or any other conditions beyond those indicated under “recommended operating conditions” is not implied. Exposure to absolute-maximum-rated conditions for extended periods may affect device reliability.

(2) If the 'DAC26 is used to drive high power levels to an 8-Ω load for extended intervals at ambient temperatures above 70°C, multiple vias should be used to electrically and thermally connect the thermal pad on the QFN package to an internal heat-dissipating ground plane on the user's PCB.

## ELECTRICAL CHARACTERISTICS

At +25°C, AVDD, DRVDD, IOVDD = 3.3 V, DVDD = 1.8 V, Int. V<sub>ref</sub> = 2.5 V, Fs (Audio) = 48 kHz, unless otherwise noted

PARAMETER	TEST CONDITIONS	MIN	TYP	MAX	UNITS
<b>MICROPHONE INPUT</b>					
Input resistance			20		kΩ
Input capacitance			10		pF
<b>MICROPHONE BIAS</b>					
Voltage	D4 = 0 control register 05H/Page2		2.5		V
	D4 = 1 control register 05H/Page2		2.0		V
Sourcing current			4.7		mA

## ELECTRICAL CHARACTERISTICS

At +25°C, AVDD,DRVDD,IOVDD = 3.3 V, DVDD = 1.8 V, Int. V<sub>ref</sub> = 2.5 V, Fs (Audio) = 48 kHz, unless otherwise noted (continued)

PARAMETER	TEST CONDITIONS	MIN	TYP	MAX	UNITS
<b>DAC INTERPOLATION FILTER</b>					
Pass band		20		0.45 Fs	Hz
Pass band ripple			±0.06		dB
Transition band		0.45 Fs		0.5501 Fs	Hz
Stop band		0.5501 Fs		7.455 Fs	Hz
Stop band attenuation			65		dB
Filter group delay			21/Fs		sec
De-emphasis error			±0.1		dB
<b>DAC LINE OUTPUT</b>					
	1-kHz sine wave input, 48 ksps, output drivers in low power mode, load = 10 kΩ, 10 pF				
Full scale output voltage (0 dB)	By design, D10–D9 = 00 in control register 06H/Page2 corresponding to 2-V <sub>pp</sub> output swing		0.707		Vrms
Output common mode	By design, D10–D9 = 00 in control register 06H/Page2 corresponding to 2-V <sub>pp</sub> output swing		1.35		V
SNR	Measured as idle channel noise, A-weighted	85	97		dBA
THD	0-dB FS input, 0-dB gain		–95		dB
PSRR	1 kHz, 100 mV <sub>pp</sub> on AVDD <sup>(2)</sup> VGND powered down		56		dB
<b>DAC HEADPHONE OUTPUT</b>					
	1-kHz sine wave input, 48 ksps, output drivers in high power mode, load = 16 Ω, 10 pF				
Full scale output voltage (0 dB)	By design, D10–D9 = 00 in control register 06H/Page2 corresponding to 2-V <sub>pp</sub> output swing		0.707		Vrms
SNR	Measured as idle channel noise, A-weighted	85	97		dBA
THD	–1 dB FS input, 0-dB gain		–91	–55	dB
PSRR	1 kHz, 100 mV <sub>pp</sub> on AVDD <sup>(1)</sup> VGND powered down		54		dB
Mute attenuation			121		dB
Maximum output power	D10–D9 = 00 in control register 06H/Page2		30		mW
Digital volume control gain		–63.5		0	dB
Digital volume control step size			0.5		dB
Channel separation	Between HPL and HPR		80		dB
<b>DAC SPEAKER OUTPUT</b>					
	Output driver in high power mode, load = 8 Ω, connected between HPR and HPL pins. D10–D9 = 10 in control register 06H/Page2 corresponding to 2.402-V <sub>pp</sub> output swing				
Output power	0 dB input to DAC		325		mW
SNR	Measured as idle channel noise, A-weighted		102		dBA
THD	–1 dB FS input, 0-dB gain		–86		dB
	–6 dB FS input, 0-dB gain		–88		dB

(1) DAC PSRR measurement is calculated as:

$$PSRR = 20 \log_{10} \left( \frac{V_{SIG_{sup}}}{V_{HPR/L}} \right)$$

**ELECTRICAL CHARACTERISTICS**

 At +25°C, AVDD,DRVDD,IOVDD = 3.3 V, DVDD = 1.8 V, Int. V<sub>ref</sub> = 2.5 V, Fs (Audio) = 48 kHz, unless otherwise noted (continued)

PARAMETER	TEST CONDITIONS	MIN	TYP	MAX	UNITS
<b>VOLTAGE REFERENCE</b>					
Voltage range	VREF output programmed as 2.5 V	2.3	2.5	2.7	V
	VREF output programmed as 1.25 V	1.15	1.25	1.35	
Voltage range	External VREF. By design, not tested in production.	1.2		2.55	V
Reference drift	Internal VREF = 1.25 V		29		ppm/°C
Current drain	Extra current drawn when the internal reference is turned on.		650		μA
<b>DIGITAL INPUT / OUTPUT(1)</b>					
Internal clock frequency			8.8		MHz
Logic family			CMOS		
Logic level: V <sub>IH</sub>	I <sub>IH</sub> = +5 μA	0.7xIOVDD			V
V <sub>IL</sub>	I <sub>IL</sub> = +5 μA	-0.3		0.3xIOVDD	V
V <sub>OH</sub>	I <sub>OH</sub> = 2 TTL loads	0.8xIOVDD			V
V <sub>OL</sub>	I <sub>OL</sub> = 2 TTL loads			0.1xIOVDD	V
Capacitive load			10		pF
<b>POWER SUPPLY REQUIREMENTS</b>					
Power supply voltage					
AVDD(2)		2.7		3.6	V
DRVDD(2)		2.7		3.6	v
IOVDD		1.1		3.6	V
DVDD		1.525		1.95	V
Stereo audio playback	I <sub>AVDD</sub>	48 ksps, output drivers in low power mode, VGND off, PLL off	2.2		mA
	I <sub>DRVDD</sub>		0		
	I <sub>DVDD</sub>		2.4		
PLL	I <sub>AVDD</sub>	Additional power consumed when PLL is enabled.	0.1		mA
	I <sub>DRVDD</sub>		1.3		
	I <sub>DVDD</sub>		0.9		
VGND	I <sub>AVDD</sub>	Additional power consumed when VGND is powered.	0.3		mA
	I <sub>DRVDD</sub>		0.9		
	I <sub>DVDD</sub>		0		
Hardware power down	All currents		2		μA

(1) Internal oscillator is designed to give nominally 8-MHz clock frequency. However, due to process variations, this frequency can vary from device to device. All calculations for delays and wait times in the data sheet assume an 8-MHz oscillator clock.

(2) It is recommended that AVDD and DRVDD be set to the same voltage for the best performance. It is also recommended that these supplies be separated on the user's PCB.

FUNCTIONAL BLOCK DIAGRAM

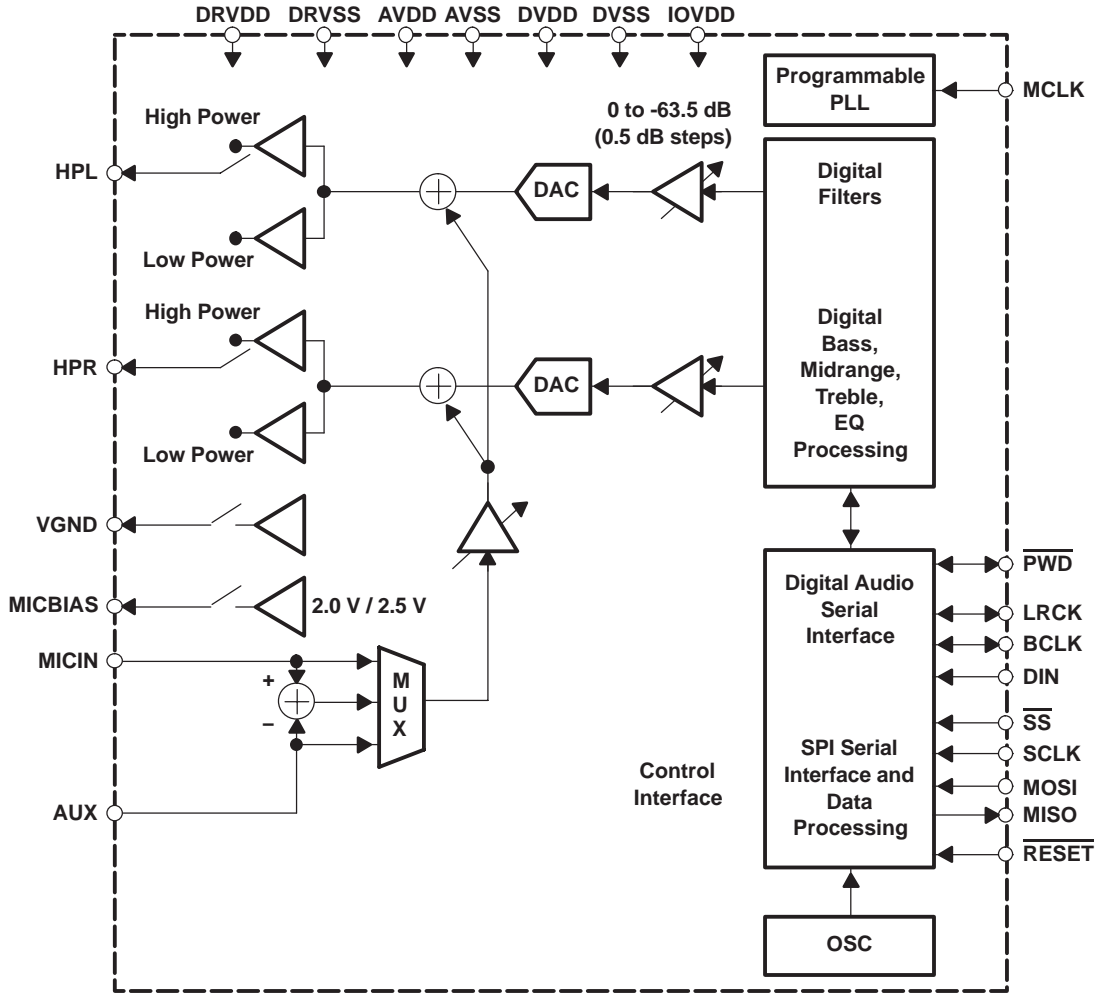

**SPI TIMING DIAGRAM**

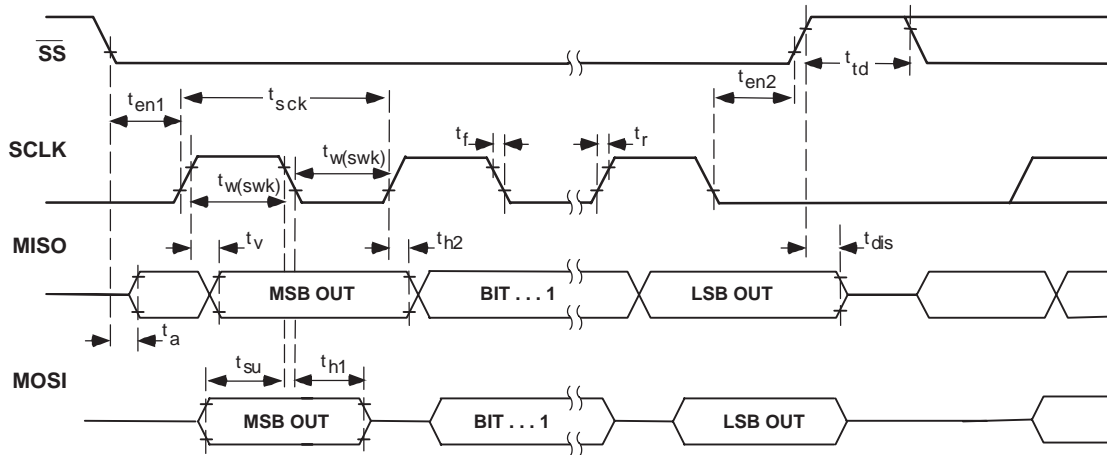

**TYPICAL TIMING REQUIREMENTS**

All specifications at 25°C, DVDD = 1.8 V (1)

PARAMETER	IOVDD = 1.1 V		IOVDD = 3.3 V		UNITS
	MIN	MAX	MIN	MAX	
$t_{w(sck)}$ SCLK pulse width	27		18		ns
$t_{en1}$ Enable lead time	18		15		ns
$t_{en2}$ Enable lag time	18		15		ns
$t_d$ Sequential transfer delay time	18		15		ns
$t_a$ Slave MISO access time		18		15	ns
$t_{dis}$ Slave MISO disable time		18		15	ns
$t_{su}$ MOSI data setup time	6		6		ns
$t_{h1}$ MOSI data hold time	6		6		ns
$t_{h2}$ MISO data hold time		4		4	ns
$t_v$ MISO data valid time		22		13	ns
$t_r$ Rise time		6		4	ns
$t_f$ Fall time		6		4	ns

(1) These parameters are based on characterization and are not tested in production.

**AUDIO INTERFACE TIMING DIAGRAMS**

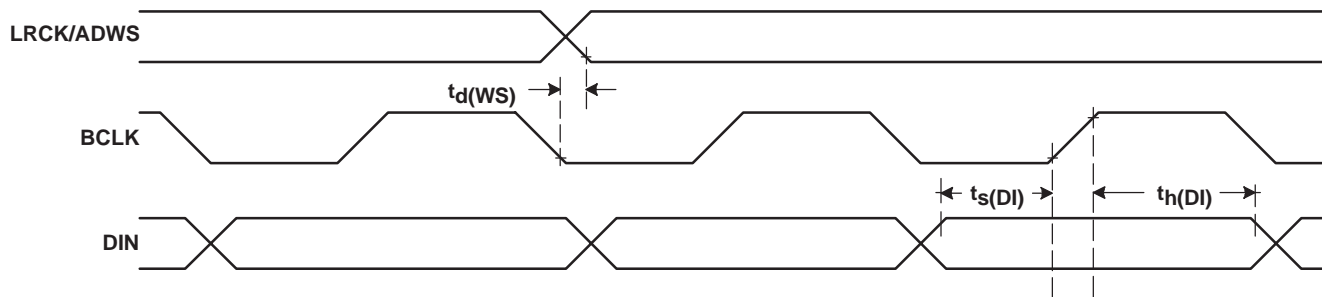

**Figure 1. I<sup>2</sup>S/LJF/RJF Timing in Master Mode**

**TYPICAL TIMING REQUIREMENTS (FIGURE 1)**

All specifications at 25°C, DVDD = 1.8 V <sup>(1)</sup>

PARAMETER	IOVDD = 1.1 V		IOVDD = 3.3 V		UNITS
	MIN	MAX	MIN	MAX	
t <sub>d</sub> (WS)      LRCK delay time		25		15	ns
t <sub>s</sub> (DI)      DIN setup time	6		6		ns
t <sub>h</sub> (DI)      DIN hold time	6		6		ns
t <sub>r</sub> Rise time		10		6	ns
t <sub>f</sub> Fall time		10		6	ns

<sup>(1)</sup> These parameters are based on characterization and are not tested in production.

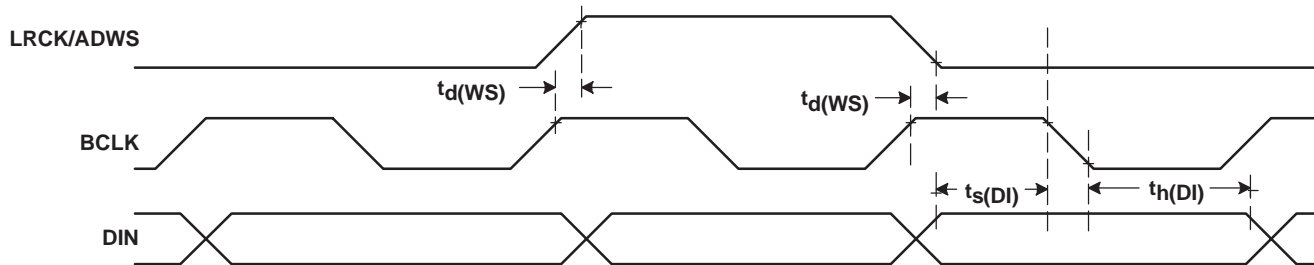

**Figure 2. DSP Timing in Master Mode**

**TYPICAL TIMING REQUIREMENTS (FIGURE 2)**

All specifications at 25°C, DVDD = 1.8 V <sup>(1)</sup>

PARAMETER	IOVDD = 1.1 V		IOVDD = 3.3 V		UNITS
	MIN	MAX	MIN	MAX	
t <sub>d</sub> (WS)      LRCK delay time		25		15	ns
t <sub>s</sub> (DI)      DIN setup time	6		6		ns
t <sub>h</sub> (DI)      DIN hold time	6		6		ns
t <sub>r</sub> Rise time		10		6	ns
t <sub>f</sub> Fall time		10		6	ns

<sup>(1)</sup> These parameters are based on characterization and are not tested in production.



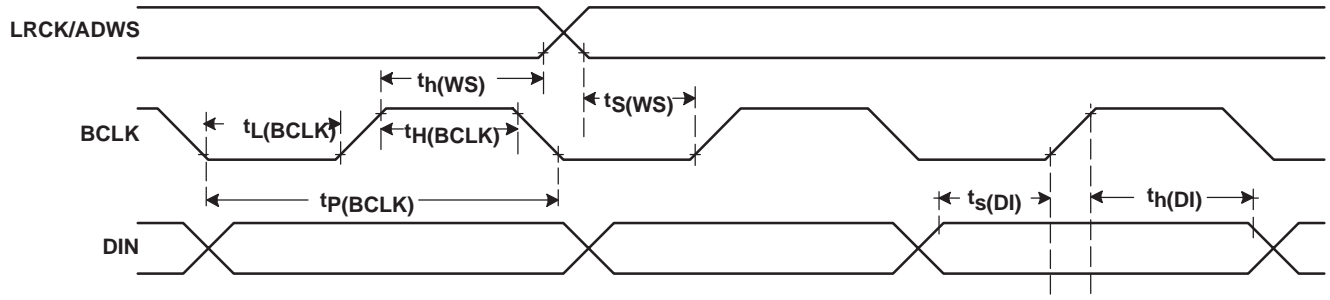

**Figure 3. I<sup>2</sup>S/LJF/RJF Timing in Slave Mode**

**TYPICAL TIMING REQUIREMENTS (FIGURE 3)**

All specifications at 25°C, DVDD = 1.8 V <sup>(1)</sup>

PARAMETER		IOVDD = 1.1 V		IOVDD = 3.3 V		UNITS
		MIN	MAX	MIN	MAX	
t <sub>H</sub> (BCLK)	BCLK high period time	35		35		ns
t <sub>L</sub> (BCLK)	BCLK low period time	35		35		ns
t <sub>S</sub> (WS)	LRCK setup time	6		6		ns
t <sub>H</sub> (WS)	LRCK hold time	6		6		ns
t <sub>S</sub> (DI)	DIN setup time	6		6		ns
t <sub>H</sub> (DI)	DIN hold time	6		6		ns
t <sub>r</sub>	Rise time		5		4	ns
t <sub>f</sub>	Fall time		5		4	ns

<sup>(1)</sup> These parameters are based on characterization and are not tested in production.

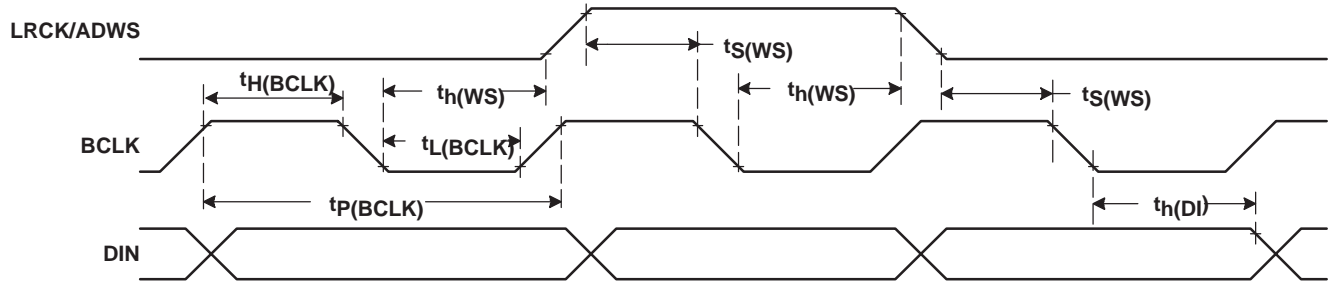

Figure 4. DSP Timing in Slave Mode

**TYPICAL TIMING REQUIREMENTS (FIGURE 4)**

All specifications at 25°C, DVDD = 1.8 V (1)

PARAMETER		IOVDD = 1.1 V		IOVDD = 3.3 V		UNITS
		MIN	MAX	MIN	MAX	
$t_H(BCLK)$	BCLK high period	35		35		ns
$t_L(BCLK)$	BCLK low period	35		35		ns
$t_S(WS)$	LRCK setup time	6		6		ns
$t_H(WS)$	LRCK hold time	6		6		ns
$t_S(DI)$	DIN setup time	6		6		ns
$t_H(DI)$	DIN hold time	6		6		ns
$t_r$	Rise time		5		4	ns
$t_f$	Fall time		5		4	ns

(1) These parameters are based on characterization and are not tested in production.

**TYPICAL CHARACTERISTICS**

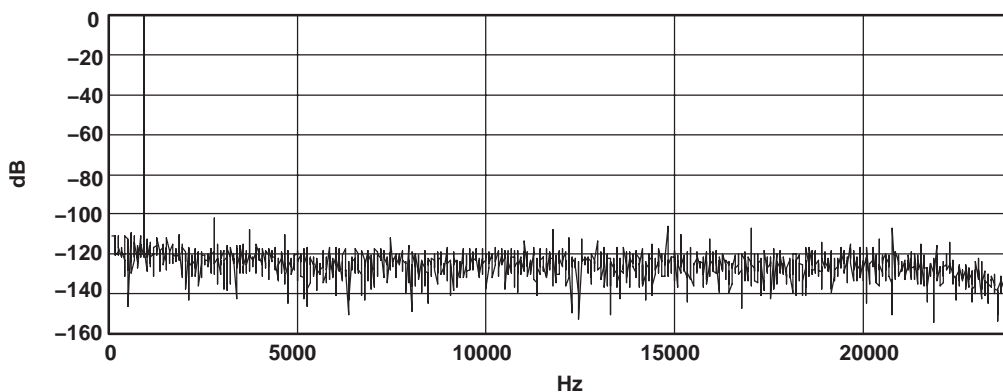

**Figure 5. DAC FFT Plot ( $T_A = 25^\circ\text{C}$ , 48 ksp/s, 0 dB, 1 kHz Input,  $AVDD = 3.3\text{ V}$ ,  $R_L = 10\text{ k}\Omega$ )**

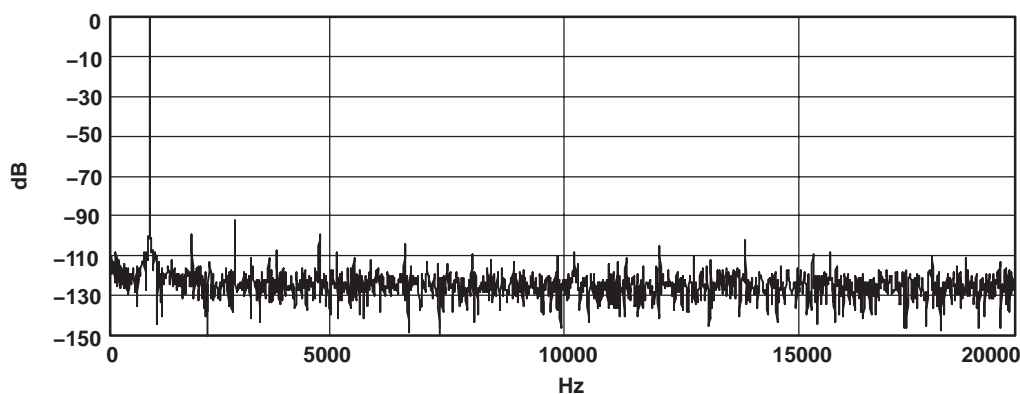

**Figure 6. DAC FFT Plot ( $T_A = 25^\circ\text{C}$ , 48 ksp/s, -1 dB, 1 kHz Input,  $AVDD = DRVDD = 3.3\text{ V}$ ,  $DVDD = 1.8\text{ V}$ ,  $R_L = 16\ \Omega$ )**

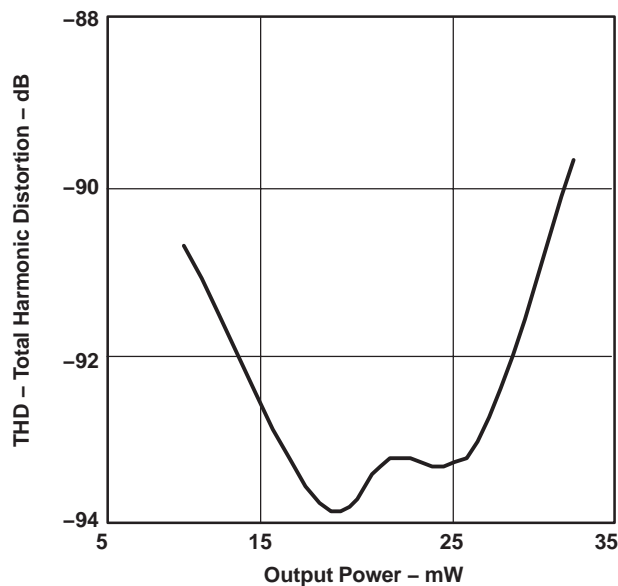

**Figure 7. High Power Output Driver THD vs Output Power ( $T_A = 25^\circ\text{C}$ ,  $AVDD, DRVDD = 3.3\text{ V}$ ,  $R_L = 16\ \Omega$ )**

## OVERVIEW

The TLV320DAC26 is a highly integrated stereo audio DAC for portable computing, communication, and entertainment applications. The 'DAC26 has a register-based architecture where all functions are controlled through the registers and onboard state machines.

The 'DAC26 consists of the following blocks (refer to the block diagram):

- Audio DAC
- Auxiliary Inputs for analog pass through functionality

Audio data is transferred between the host DSP/μP via a standard 4-wire interface and supports a variety of modes (i.e., I<sup>2</sup>S, DSP, etc).

Control of the 'DAC26 and its functions is accomplished by writing to different registers in the 'DAC26. A simple command protocol is used to address the 16-bit registers. Registers control the operation of the audio DAC. The control and auxiliary functions are accessed via a SPI bus.

A typical application of the 'DAC26 is shown in Figure 8.

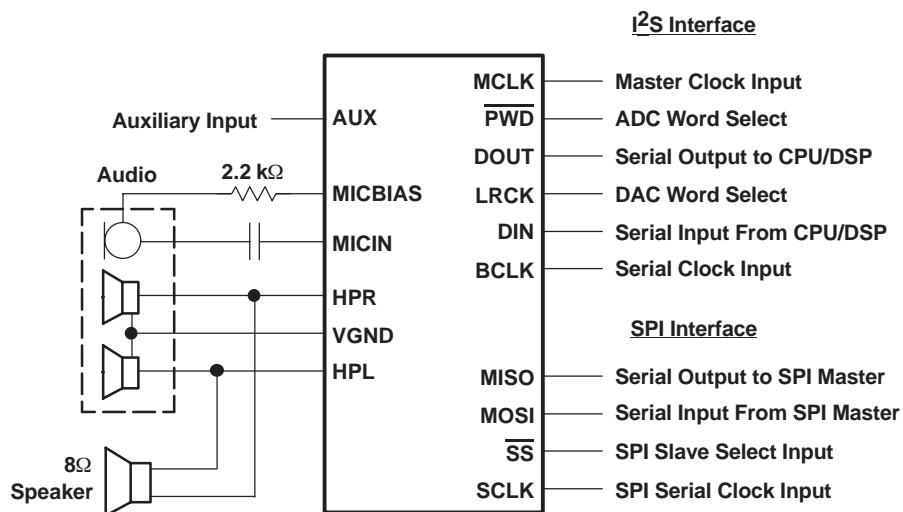

Figure 8. Typical Circuit Configuration

## OPERATION–AUDIO DAC

### Audio Analog I/O

The 'DAC26 has one mono audio input (MICIN) typically used for microphone recording, and an auxiliary input (AUX) that can be used as a second microphone or line input. The 'DAC26 has an analog pass through mode where by the input from the Mic and AUX input can be routed to any one of the analog output drivers. The dual audio output drivers have programmable power level and can be configured to drive up to 325 mW into an 8- $\Omega$  speaker, or to drive 16- $\Omega$  stereo headphones at over 30-mW per channel, or to provide a stereo line-level output. The power level of the output drivers is controlled using bit D12 in control register REG–05H/Page2. The 'DAC26 also has a virtual ground (VGND) output driver, which can optionally be used to connect the return terminal of headphones, to eliminate the ac-coupling capacitors needed at the headphone output. The VGND amplifier is controlled by bit D8 of REG–05H/Page2. A special circuit has also been included in the 'DAC26 to insert a short keyclick sound into the stereo audio output, even when the audio DAC is powered down. The keyclick sound is used to provide feedback to the user when a particular button is pressed or item is selected. The specific sound of the keyclick can be adjusted by varying several register bits that control its frequency, duration, and amplitude.

### Audio Digital Interface

Digital audio data samples are transmitted between the 'DAC26 and the audio processor via the serial bus (BCLK, LRCK, DIN) that can be configured to transfer digital data in four different formats: right justified, left justified, I<sup>2</sup>S, and DSP. The four modes are MSB-first and operate with variable word length of 16, 20, 24, or 32 bits. The digital audio serial bus of the 'DAC26 can operate in master or slave mode, depending on its register settings. The word-select signal (LRCK) and bit clock signal (BCLK) are configured as outputs when the bus is in master mode. They are configured as inputs when the bus is in slave mode. The LRCK is representative of the audio DAC sampling rate and is synchronized with DIN.

#### ● DAC SAMPLING RATE

The Audio Control 1 register (Register 00H, Page2) determines the sampling rates of the audio DAC, which is scaled down from a reference rate (Fsref). When the audio DAC is powered up, it is configured by default as an I<sup>2</sup>S slave with the DAC operating at Fsref.

#### ● WORD SELECT SIGNALS

The word select signal (LRCK) indicates the channel being transmitted:

- LRCK = 0: left channel for I<sup>2</sup>S mode
- LRCK = 1: right channel for I<sup>2</sup>S mode

For other modes see the timing diagrams below.

### Bitclock (BCLK) Signal

In addition to flexibility as master or slave mode, the BCLK can also be configured in two transfer modes—256–S and Continuous Transfer Modes. These modes are set using bit D12/REG–06h/Page2.

#### ● 256–S TRANSFER MODE

In the 256–S mode, the BCLK rate always equals 256 times the maximum of the LRCK frequencies. In the 256–S mode, the DAC sampling rate equal to Fsref (as selected by bit D5–D0/REG–00h/Page2) and left-justified mode is not supported.

#### ● CONTINUOUS TRANSFER MODE

In the continuous transfer mode, the BCLK rate always equals two times the word length of the maximum of the LRCK frequencies.

● **RIGHT-JUSTIFIED MODE**

In right-justified mode, the LSB of the left channel is valid on the rising edge of the BCLK preceding the falling edge of LRCK. Similarly, the LSB of the right channel is valid on the rising edge of the BCLK preceding the rising edge of LRCK.

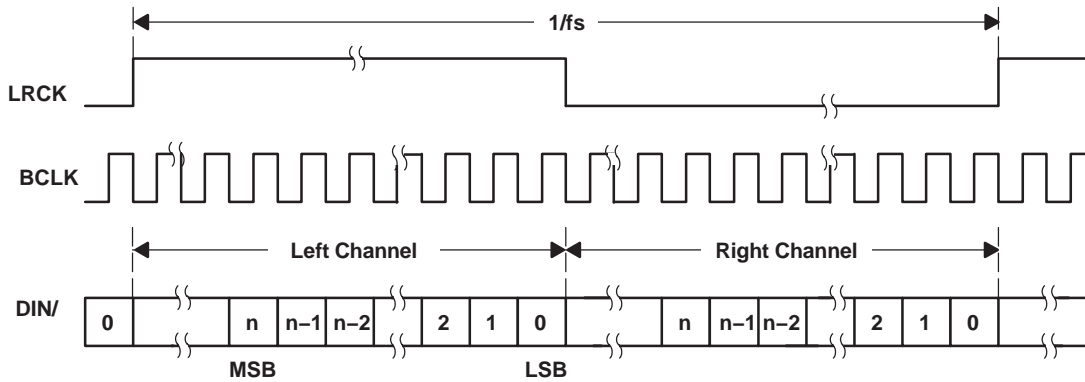

Figure 9. Timing Diagram for Right-Justified Mode

● **LEFT-JUSTIFIED MODE**

In left-justified mode, the MSB of the right channel is valid on the rising edge of the BCLK, following the falling edge of ADWS or LRCK. Similarly the MSB of the left channel is valid on the rising edge of the BCLK following the rising edge of ADWS or LRCK.

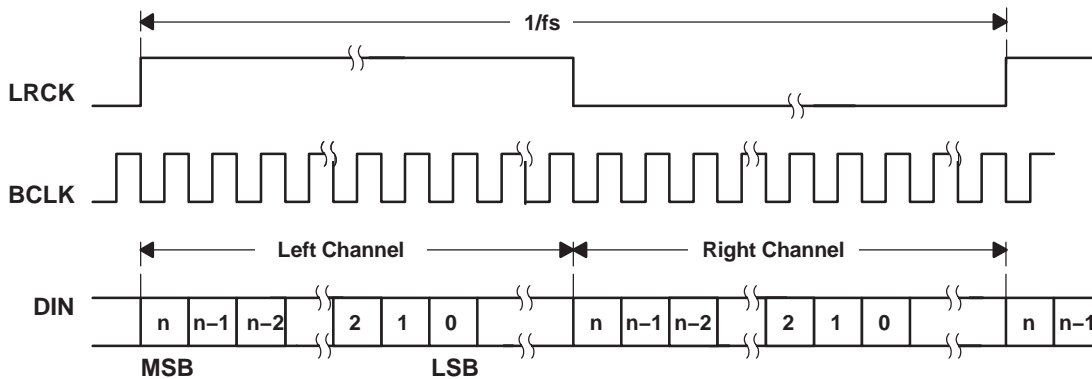
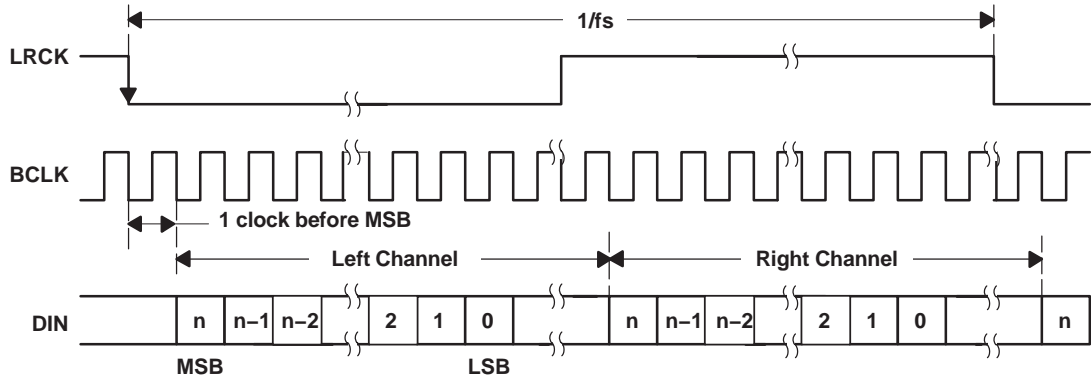

Figure 10. Timing Diagram for Left-Justified Mode

● **I<sup>2</sup>S MODE**

In I<sup>2</sup>S mode, the MSB of the left channel is valid on the second rising edge of the BCLK after the falling edge of ADWS or LRCK. Similarly the MSB of the right channel is valid on the second rising edge of the BCLK after the rising edge of LRCK.



**Figure 11. Timing Diagram for I<sup>2</sup>S Mode**

● **DSP MODE**

In DSP mode, the falling edge of LRCK starts the data transfer with the left channel data first and immediately followed by the right channel data. Each data bit is valid on the falling edge of BCLK.

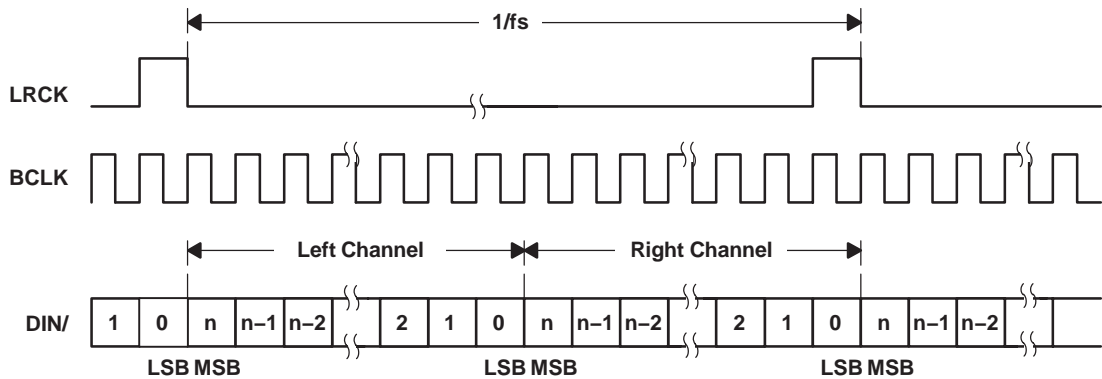

**Figure 12. Timing Diagram for DSP Mode**

## AUDIO DATA CONVERTERS

The 'DAC26 has a stereo audio DAC. The DAC can operate with a maximum sampling rate of 53 kHz and support all audio standard rates of 8 kHz, 11.025 kHz, 12 kHz, 16 kHz, 22.05 kHz, 24 kHz, 32 kHz, 44.1 kHz, and 48 kHz. By utilizing the flexible clock generation capability and internal programmable interpolation, a wide variety of sampling rates up to 53 kHz can be obtained from many possible MCLK inputs.

When the DAC is operating, the 'DAC26 requires an applied audio MCLK input. The user should also set bit D13/REG–06H/Page2 to indicate which Fsref rate is being used.

Typical audio DACs can suffer from poor out-of-band noise performance when operated at low sampling rates, such as 8 kHz or 11.025 kHz. The 'DAC26 includes programmable interpolation circuitry to provide improved audio performance at such low sampling rates, by first upsampling low-rate data to a higher rate, filtering to reduce audible images, and then passing the data to the internal DAC, which is actually operating at the Fsref rate. This programmable interpolation is determined using bit D5–D3/REG–00H/Page2.

For example, if playback of 11.025-kHz data is required, the 'DAC26 can be configured such that Fsref = 44.1 kHz. Then using bit D5–D3/REG–00H/Page2, the DAC sampling rate (Fs) can be set to Fsref/4, or Fs = 11.025 kHz. In operation, the 11.025-kHz digital input data is received by the 'DAC26, upsampled to 44.1 kHz, and filtered for images. It is then provided to the audio DAC operating at 44.1 kHz for playback. In reality, the audio DAC further upsamples the 44.1 kHz data by a ratio of 128x and performs extensive interpolation filtering and processing on this data before conversion to a stereo analog output signal.

### PLL

The 'DAC26 has an on-chip PLL to generate the needed internal DAC operational clocks from a wide variety of clocks available in the system. The PLL supports an MCLK varying from 2 MHz to 50 MHz and is register programmable to enable generation of required sampling rates with fine precision.

DAC sampling rates are given by

$$\text{DAC\_FS} = \text{Fsref}/N1$$

where, Fsref must fall between 39 kHz and 53 kHz, and N1, N2 =1, 1.5, 2, 3, 4, 5, 5.5, 6 are register programmable.

The PLL can be enabled or disabled using register programming.

- When PLL is disabled

$$\text{Fsref} = \frac{\text{MCLK}}{128 \times Q}$$

$$Q = 2, 3 \dots 17$$

- In this mode, the MCLK can operate up to 50 MHz, and Fsref should fall within 39 kHz to 53 kHz.

- When PLL is enabled

$$\text{Fsref} = \frac{\text{MCLK} \times K}{2048 \times P}$$

$$P = 1, 2, 3, \dots, 8$$

$$K = J.D$$

$$J = 1, 2, 3, \dots, 64$$

$$D = 0, 1, 2, \dots, 9999$$

P, J, and D are register programmable, where J is an integer part of K before the decimal point, and D is a four-digit fractional part of K after the decimal point, including lagging zeros.

Examples: If K = 8.5, Then J = 8, D = 5000  
 If K = 7.12, Then J = 7, D = 1200  
 If K = 7.012, Then J = 7, D = 120

The PLL is programmed through Registers 1BH and 1CH of Page2.



- When PLL is enabled and  $D = 0$ , the following condition must be satisfied

$$2 \text{ MHz} \leq \frac{\text{MCLK}}{P} \leq 20 \text{ MHz}$$

$$80 \text{ MHz} \leq \frac{\text{MCLK} \times K}{P} \leq 110 \text{ MHz}$$

$$4 \leq J \leq 55$$

- When PLL is enabled and  $D \neq 0$ , the following condition must be satisfied

$$10 \text{ MHz} \leq \frac{\text{MCLK}}{P} \leq 20 \text{ MHz}$$

$$80 \text{ MHz} \leq \frac{\text{MCLK} \times K}{P} \leq 110 \text{ MHz}$$

$$4 \leq J \leq 11$$

**Example 1:**

For  $\text{MCLK} = 12 \text{ MHz}$  and  $\text{Fsref} = 44.1 \text{ kHz}$

$P = 1, K = 7.5264 \Rightarrow J = 7, D = 5264$

**Example 2:**

For  $\text{MCLK} = 12 \text{ MHz}$  and  $\text{Fsref} = 48.0 \text{ kHz}$

$P = 1, K = 8.192 \Rightarrow J = 8, D = 1920$

**STEREO AUDIO DAC**

Each channel of the stereo audio DAC consists of a digital audio processing block, a digital interpolation filter, digital delta-sigma modulator, and an analog reconstruction filter. The DAC is designed to provide enhanced performance at low sample rates through increased oversampling and image filtering, thereby keeping quantization noise generated within the delta-sigma modulator and signal images strongly suppressed within the audio band to beyond 20 kHz. This is realized by keeping the upsampled rate constant at  $128 \times \text{Fsref}$  and changing the oversampling ratio as the input sample rate is changed. For  $\text{Fsref}$  of 48 kHz, the digital delta-sigma modulator always operates at a rate of 6.144 MHz. This ensures that quantization noise generated within the delta-sigma modulator stays low within the frequency band below 20 kHz at all sample rates. Similarly, for  $\text{Fsref}$  rate of 44.1 kHz, the digital delta-sigma modulator always operates at a rate of 5.6448 MHz.

**Digital Audio Processing**

The DAC channel consists of optional filters for de-emphasis and bass, treble, midrange level adjustment, or speaker equalization. The de-emphasis function is only available for sample rates of 32 kHz, 44.1 kHz, and 48 kHz. The transfer function consists of a pole with time constant of 50  $\mu\text{s}$  and a zero with time constant of 15  $\mu\text{s}$ . Frequency response plots are given in the *Audio DAC Filter Frequency Responses* section of this data sheet. The de-emphasis filter can be enabled or bypassed depending on bit D0 of register 05H/Page2.

The DAC digital effects processing block also includes a fourth order digital IIR filter with programmable coefficients (one set per channel). The filter is implemented as cascade of two biquad sections with frequency response given by:

$$\left( \frac{N_0 + 2 \times N_1 \times z^{-1} + N_2 \times z^{-2}}{32768 - 2 \times D_1 \times z^{-1} - D_2 \times z^{-2}} \right) \left( \frac{N_3 + 2 \times N_4 \times z^{-1} + N_5 \times z^{-2}}{32768 - 2 \times D_4 \times z^{-1} - D_5 \times z^{-2}} \right)$$

The N and D coefficients are fully programmable, and the entire filter can be enabled or bypassed depending on bit D1 of register 05H/Page2. The coefficients for this filter implement a variety of sound effects, with bass-boost or treble boost being the most commonly used in portable audio applications. The default N and D coefficients in the part are given by:

$N_0 = N_3 = 27619$        $D_1 = D_4 = 32131$   
 $N_1 = N_4 = -27034$      $D_2 = D_5 = -31506$   
 $N_2 = N_5 = 26461$

and implement a shelving filter with 0 dB gain from dc to approximately 150 Hz, at which point it rolls off to a 3-dB attenuation for higher frequency signals, thus giving a 3-dB boost to signals below 150 Hz. The N and D coefficients are represented by 16-bit twos complement numbers with values ranging from  $-32768$  to  $+32767$ . Frequency response plots are given in the *Audio DAC Filter Frequency Responses* section of this data sheet.

### Interpolation Filter

The interpolation filter upsamples the output of the digital audio processing block by the required oversampling ratio. It provides a linear phase output with a group delay of  $21/F_s$ .

In addition, a digital interpolation filter provides enhanced image filtering and reduces signal images caused by the upsampling process that are below 20 kHz. For example, upsampling an 8-kHz signal produces signal images at multiples of 8 kHz (i.e., 8 kHz, 16 kHz, 24 kHz, etc). The images at 8 kHz and 16 kHz are below 20 kHz and still audible to the listener; therefore, they must be filtered heavily to maintain good output quality. The interpolation filter is designed to maintain at least 65-dB rejection of images that land below  $7.455 F_s$ . In order to utilize the programmable interpolation capability, the  $F_{sref}$  should be programmed to a higher rate (restricted to be in the range of 39 kHz to 53 kHz when the PLL is in use), and the actual  $F_s$  is set using the dividers in bit D5–D3/REG–00H/Page2. For example, if  $F_s = 8$  kHz is required, then  $F_{sref}$  can be set to 48 kHz, and the DAC  $F_s$  set to  $F_{sref}/6$ . This ensures that all images of the 8-kHz data are sufficiently attenuated well beyond the  $\sim 20$ -kHz audible frequency range.

### Delta-Sigma DAC

The audio digital-to-analog converter incorporates a third order multibit delta-sigma modulator followed by an analog reconstruction filter. The DAC provides high-resolution, low-noise performance, using oversampling and noise shaping techniques. The analog reconstruction filter design consists of a 6 tap analog FIR filter followed by a continuous time RC filter. The analog FIR operates at a rate of  $128 \times F_{sref}$  (6.144 MHz when  $F_{sref} = 48$  kHz, 5.6448 MHz when  $F_{sref} = 44.1$  kHz). Note that the DAC analog performance may be degraded by excessive clock jitter on the MCLK input. Therefore, care must be taken to keep jitter on this clock to a minimum.

### DAC Digital Volume Control

The DAC has a digital volume control block, which implements programmable gain. The volume level can be varied from 0 dB to  $-63.5$  dB in 0.5 dB steps. In addition, there is an independent mute bit for each channel. The volume level of both channels can also be changed simultaneously by the master volume control. The gain is implemented with a soft-stepping algorithm, which only changes the actual volume by one step per input sample, either up or down, until the desired volume is reached. The rate of soft-stepping can be slowed to one step per two input samples through bit D1 of control register 04H/Page2.

Because of soft-stepping, the host does not know when the DAC has been actually muted. This may be important if the host wishes to mute the DAC before making a significant change, such as changing sample rates. In order to help with this situation, the 'DAC26 provides a flag back to the host via a read-only register bit (D2–D3 of control register 04H/Page2) that alerts the host when the part has completed the soft-stepping and the actual volume has reached the desired volume level. The soft-stepping feature can be disabled by programming D14=1 in register 1DH in Page02. If soft-stepping is enabled, the MCLK signal to the device should not be changed until the DAC power-down flag is set. When this flag is set, the internal soft-stepping process and power-down sequence is complete, and the MCLK can be stopped if desired.

The 'DAC26 also includes functionality to detect when the user switches are on or off the de-emphasis or digital audio processing functions, to first (1) soft-mute the DAC volume control, (2) change the operation of the digital effects processing, and (3) soft-unmute the part. This avoids any possible pop/clicks in the audio output due to instantaneous changes in the filtering. A similar algorithm is used when first powering up or down the DAC. The circuit begins operation at power up with the volume control muted, then soft-steps it up to the desired volume level. At power down, the logic first soft-steps the volume down to a mute level, then powers down the circuitry.

### DAC Power Down

The DAC power-down flag ( D6 of REG05H/Page2) along with D10 of REG05H/Page2 denotes the power-down status of the DAC according to Table 1.

**Table 1. DAC Powerdown Status**

[D10,D6]	POWERUP / DOWN STATE OF DAC
[0,0]	DAC is in stable power-up state
[0,1]	DAC is in the process of powering up. The length of this state is determined by PLL and output driver power-up delays controlled by register programming.
[1,0]	DAC is in the process of powering down. The length of this state is determined by soft-stepping of volume control block and DAC pop reduction sequencing controlled by register programming.
[1,1]	DAC is in a stable power-down state.

### AUDIO OUTPUT DRIVERS

The 'DAC26 features audio output drivers which can be configured in either low power mode or high power mode depending on the load and output power required. By default, at reset the output drivers are configured in low power mode. In this mode, the output drivers can drive a full-scale line-level signal into loads of 10 k $\Omega$  minimum or drive moderate amplitude signals into loads of 16  $\Omega$  minimum.

The output drivers can also be configured in high power mode by setting bit D12 of Reg05H/Page2 to 1. In this mode, each output driver can deliver up to 30 mW per channel into a headphone speaker load of 16  $\Omega$ . The headphones can be connected in a single-ended configuration using ac-coupling capacitors, or the capacitors can be removed and virtual ground (VGND) powered for a capless output connection. The typical headphone jack configuration for these two modes is shown in Figure 15. Note that the VGND amplifier must be powered if the capless configuration is used.

In the case of an ac-coupled output, the value of the capacitors is typically chosen based on the amount of low-frequency cut that can be tolerated. The capacitor in series with the load impedance forms a high-pass filter with  $-3$  dB cutoff frequency of  $1/(2\pi RC)$  in Hz, where R is the impedance of the headphones. Use of an overly small capacitor reduces low-frequency components in the signal output and leads to low-quality audio. When driving 16- $\Omega$  headphones, capacitors of 220- $\mu$ F (a commonly used value) result in a high-pass filter cutoff frequency of 45 Hz, although reducing these capacitors to 50  $\mu$ F results in a cutoff frequency of 199 Hz, which is generally considered noticeable when playing music. The cutoff frequency is reduced to half of the above values if 32- $\Omega$  headphones are used instead of 16  $\Omega$ .

The 'DAC26 programmable digital effects block can be used to help reduce the size of capacitors needed by implementing a low frequency boost function to help compensate for the high-pass filter introduced by the ac-coupling capacitors. For example, by using 50- $\mu$ F capacitors and setting the 'DAC26 programmable filter coefficients as shown below, the frequency response can be improved as shown in Figure 14.

Filter coefficients (use the same for both channels):

$$N0 = 32767, N1 = -32346, N2 = 31925, N3 = 32767, N4 = 0, N5 = 0$$

$$D0 = 32738, D1 = -32708, D4 = 0, D5 = 0$$

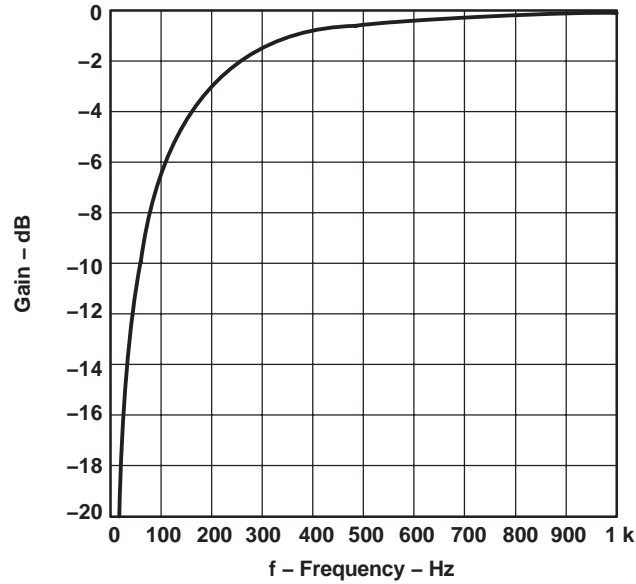

Figure 13. Uncompensated Response For 16-Ω Load and 50-μF Decoupling Capacitor

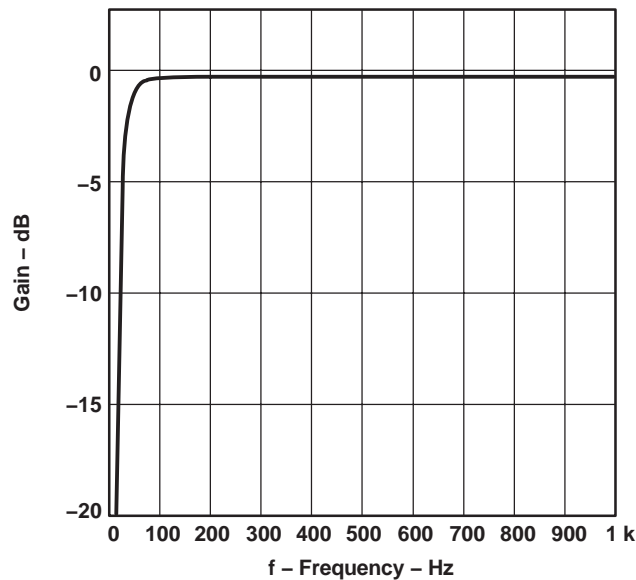

Figure 14. Frequency Response For 16-Ω Load and 50-μF Decoupling Capacitor After Gain Compensation Using a Suggested Set of Coefficients for Audio Effects Filter

Using the capless output configuration eliminates the need for these capacitors and removes the accompanying high-pass filter entirely. However, this configuration does have one drawback – if the RETURN terminal of the headphone jack (which is wired to the 'DAC26 VGND pin) is ever connected to a ground, that is shorted to the 'DAC26 ground pin, then the VGND amplifier enters short-circuit protection, and the audio output does not function properly.

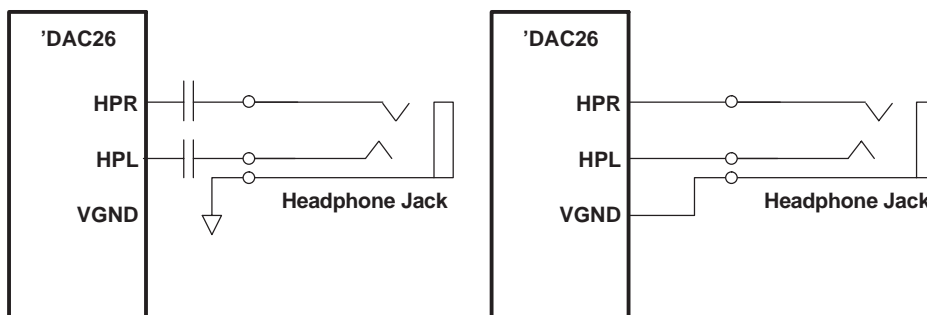

Figure 15. Headphone Configurations, AC-Coupled (left) and Capless (right)

The audio output drivers in high power mode can also be configured to drive a mono differential signal into a speaker load of 8-Ω minimum. The speaker load should be connected differentially between the HPR and HPL outputs. Several options are possible for playback of DAC data in this case. If a stereo digital signal is available, this signal can be sent in normal stereo fashion to the audio DAC. The programmable digital effects filters can then be used to invert one channel, so that the signal applied across the speaker load is (LEFT + RIGHT), or effectively a mono-mix of the two channels. A simple example of how to implement this inversion using the programmable filters is to set the coefficients as follows:

Left-channel coefficients: N0=32767, N1=0, N2=0, N3=32767, N4=0, N5=0  
D1=0, D2=0, D4=0, D5=0

Right-channel coefficients: N0=-32767, N1=0, N2=0, N3=32767, N4=0, N5=0  
D1=0, D2=0, D4=0, D5=0

This provides no spectral shaping; it only inverts the right channel relative to the left channel, such that the signals at HPL and HPR are (LEFT) and (-RIGHT), with the signal across the speaker then being LEFT+ RIGHT. In a general case when spectral shaping is also desired, the inversion can be accomplished simply by setting N0, N1, and N2 coefficients of one channel to the negative of the values set for the other channel. Note that the programmable filtering must be enabled by setting bit D1/REG-05H/Page2 to 1.

To enable the output drivers to deliver higher output power, the DAC output swing should be set to its highest level by setting bit D10-D9/REG-06H/Page2 to 11. It is possible to increase power even further by disabling the built-in short-circuit protection by programming bit D8 of Reg1DH/Page2 to 1. In this case care must be taken so a short-circuit at the output does not occur. Figure 16 shows a typical jack configuration using a capless output configuration. In this configuration, the 'DAC26 drives the loudspeaker whenever headphones are not inserted in the jack and drives the headphones whenever it is inserted in the jack.

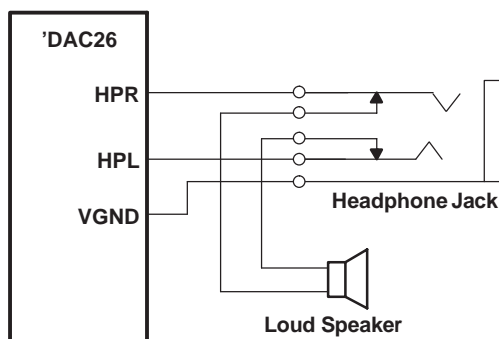

Figure 16. Speaker Connection

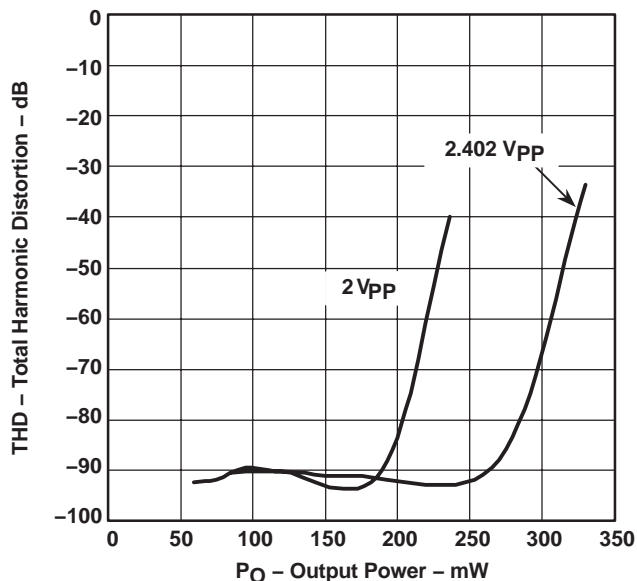

Figure 17. THD vs Output Power Delivered to an an 8-Ω Load (25°C, AVDD = DRVDD = 3.3 V, DVDD = 1.8 V, DAC Output Swing Set to 2 V and 2.4V, and Short-Circuit Protection Disabled)

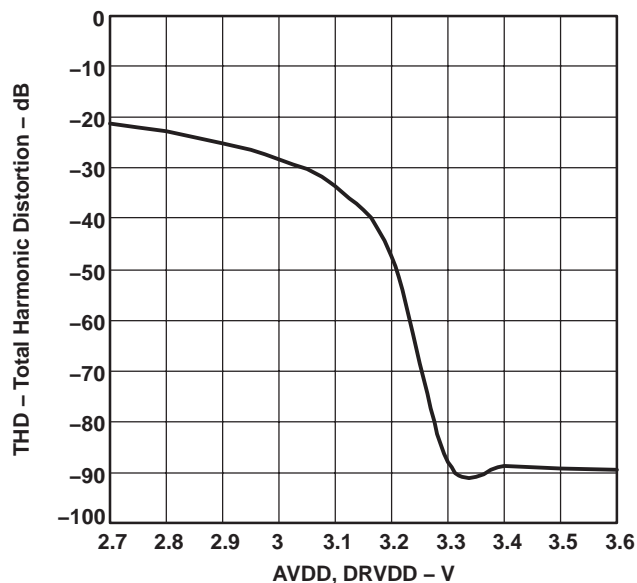

Figure 18. THD vs AVDD, DRVDD Supply Voltage (25°C When Driving a -1 dB, 1-kHz Sinewave From the DAC Into an 8-Ω Load, with DAC Output Swing Set to 2.4 V, and Short-Circuit Protection Disabled)

The 'DAC26 incorporates a programmable short-circuit detection/protection function with different modes of operation. During the insertion or removal of a headphone plug from the jack, the output pins of the drivers may be accidentally shorted, causing the part to potentially draw a huge current, which may cause the power supply voltages to dip. Bits D8–D7 of REG–1DH/Page2 control how the short-circuit detection/protection operates in the 'DAC26. One option is to fully disable short-circuit protection, which also enables the audio output drivers to deliver more power to a low-impedance load (such as an 8-Ω speaker). However, care must be taken to prevent any short-circuit from occurring while the part is in this mode.

A second programmable configuration enables current-limiting in the audio output drivers, so that excessive currents cannot be provided if the outputs are shorted. It also enables the internal short-circuit detection function, which can detect excess current being drawn from the drivers and set a short-circuit detect flag (Page2, REG–1DH, bit D6). This flag can be read by the user to power down the drivers if desired. This flag is cleared only if the short-circuit condition is removed. If the user does not monitor this flag and powers down the drivers when a short-circuit occurs, the current-limiting prevents excessive currents from being drawn, but power dissipation is higher due to this limited current flowing through the short.

In a third programmable configuration, the 'DAC26 can be programmed to monitor and automatically power down the audio output drivers upon detection of a short-circuit condition (Page2, REG–1DH, bit D7), in addition to setting the short-circuit flag in Page2, REG–1DH, bit–D6. When the device has detected a short and resulted in this condition, the short-circuit flag is cleared when all the routings to the speaker driver are disabled (i.e., DAC, Analog Mixer, and Keyclick blocks are powered down by user).

## **AUDIO OUTPUT DRIVER POWER-ON POP REDUCTION SCHEME**

The 'DAC26 implements a pop reduction scheme to reduce audible artifacts during power up and power down of the audio output drivers. This scheme can be controlled by programming bits D2 and D1 of REG1EH/Page2. By default, the driver pop reduction scheme is enabled and can be disabled by programming bit D2 of Reg1EH/Page2 to 1. When this scheme is enabled and the virtual ground connection is not used (VGND amplifier is powered down), the audio output driver slowly charges up any external ac-coupling capacitors to reduce audible artifacts. Bit D1 of REG1EH/Page2 provides control of the charging time for the ac-coupling capacitor as either 0.8 sec or 4 sec. When the virtual ground amplifier is powered up and used, the external ac-coupling capacitor is eliminated, and the power up time becomes 1 ms. This scheme takes effect whenever the audio output drivers are powered up due to enabling any of the DAC, the Analog Mixer, or the Keyclick Generator.

### **Pop Reduction for DAC Routing**

Whenever the audio DAC is powered on or off, a slight change in the output dc offset voltage may occur and can be heard as a weak pop in the output. In order to reduce this artifact, the 'DAC26 implements a DAC pop reduction scheme, which is programmable using bits D5–D2 in REG–1DH/Page2. Bit D5 enables the scheme, which implements a slow transition between the starting dc level and the final dc level. For best results, program bits D4–D2 in REG1DH/Page2 to 100.

## **AUDIO MIXING**

### **Analog Mixer**

The analog mixer can be used to route the analog input selected (MICIN or AUX) through an analog volume control and then mix it with the audio DAC output. The analog mixer feature is available only if single-ended MICIN or AUX is selected as the input. This feature is available even if the DAC is powered down. The analog volume control in this path has a gain range from 12 dB to –34.5 dB in 0.5-dB steps plus mute and includes soft-stepping logic. The internal oscillator is used for soft-stepping whenever the DAC is powered down.

## **KEYCLICK**

A special circuit has been included for inserting a square-wave signal into the analog output signal path based on register control. This functionality is intended for generating keyclick sounds for user feedback. Register 04H/Page2 contains bits that control the amplitude, frequency, and duration of the square-wave signal. The frequency of the signal can be varied from 62.5 Hz to 8 kHz and its duration can be programmed from 2 periods to 32 periods. Whenever this register is written, the square-wave is generated and coupled into the audio output, going to both audio outputs. The keyclick enable bit D15 of control register 04H/Page2 is reset after the duration of keyclick is played out. This capability is available even when the DAC is powered down.

## SPI DIGITAL INTERFACE

All 'DAC26 control registers are programmed through a standard SPI bus. The SPI allows full-duplex, synchronous, serial communication between a host processor (the master) and peripheral devices (slaves). The SPI master generates the synchronizing clock and initiates transmissions. The SPI slave devices depend on a master to start and synchronize transmissions.

A transmission begins when initiated by a master SPI. The byte from the master SPI begins shifting in on the slave SPIDIN (MOSI) pin under the control of the master serial clock. As the byte shifts in on the SPIDIN pin, a byte shifts out on the SPIDOUT (MISO) pin to the master shift register.

The idle state of the serial clock for the 'DAC26 is low, which corresponds to a clock polarity setting of 0 (typical microprocessor SPI control bit CPOL = 0). The 'DAC26 interface is designed so that with a clock phase bit setting of 1 (typical microprocessor SPI control bit CPHA = 1), the master begins driving its MOSI pin and the slave begins driving its SPIDOUT pin on the first serial clock edge. The  $\overline{SS}$  pin can remain low between transmissions; however, the 'DAC26 only interprets command words which are transmitted after the falling edge of  $\overline{SS}$ .

### Hardware Reset

The device requires a low-to-high pulse on  $\overline{RESET}$  after power up for correct operation. A hardware reset pulse initializes all the internal registers, counters, and logic.

### Hardware Power Down

By default the  $\overline{PWD}$  pin is configured as a hardware power-down (active low) signal. The device powers down all the internal circuitry to save power. All the register contents are maintained. Some counters maintain their value.



## 'DAC26 COMMUNICATION PROTOCOL

### Register Programming

The 'DAC26 is entirely controlled by registers. An SPI master controls the reading and writing of these registers by the use of a 16-bit command, which is sent prior to the data for that register. The command is constructed as shown in Figure 19.

The command word begins with a R/W bit, which specifies the direction of data flow on the SPI serial bus. The following four bits specify the page of memory this command is directed to, as shown in Table 2. The next six bits specify the register address on that page of memory to which the data is directed. The last five bits are reserved for future use and should be written only with zeros.

**Table 2. Page Addressing**

PG3	PG2	PG1	PG0	PAGE ADDRESSED
0	0	0	0	0
0	0	0	1	1
0	0	1	0	2
0	0	1	1	Reserved
0	1	0	0	Reserved
0	1	0	1	Reserved
0	1	1	0	Reserved
0	1	1	1	Reserved
1	0	0	0	Reserved
1	0	0	1	Reserved
1	0	1	0	Reserved
1	0	1	1	Reserved
1	1	0	0	Reserved
1	1	0	1	Reserved
1	1	1	0	Reserved
1	1	1	1	Reserved

To read all the first page of memory, for example, the host processor must send the command 0x8000 to the 'DAC26 – this specifies a read operation beginning at page 0, address 0. The processor can then start clocking data out of the 'DAC26. The 'DAC26 automatically increments its address pointer to the end of the page; if the host processor continues clocking data out past the end of a page, the 'DAC26 sends back the value 0xFFFF.

Likewise, writing to page 1 of memory consists of the processor writing the command 0x0800, which specifies a write operation, with PG0 set to 1, and all the ADDR bits set to 0. This results in the address pointer pointing at the first location in memory on Page 1. See the section on the 'DAC26 memory map for details of register locations

BIT 15 MSB	BIT 14	BIT 13	BIT 12	BIT 11	BIT 10	BIT 9	BIT 8	BIT 7	BIT 6	BIT 5	BIT 4	BIT 3	BIT 2	BIT 1	BIT 0 LSB
R/W*	PG3	PG2	PG1	PG0	ADDR5	ADDR4	ADDR3	ADDR2	ADDR1	ADDR0	0	0	0	0	0

**Figure 19. 'DAC26 Command Word**

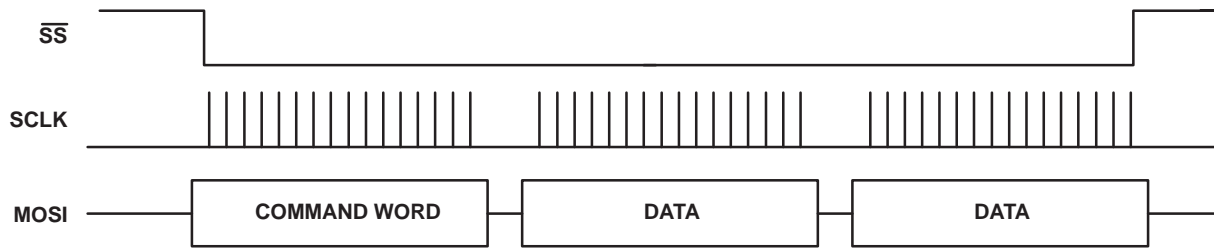

Figure 20. Write Operation for 'DAC26 SPI Interface

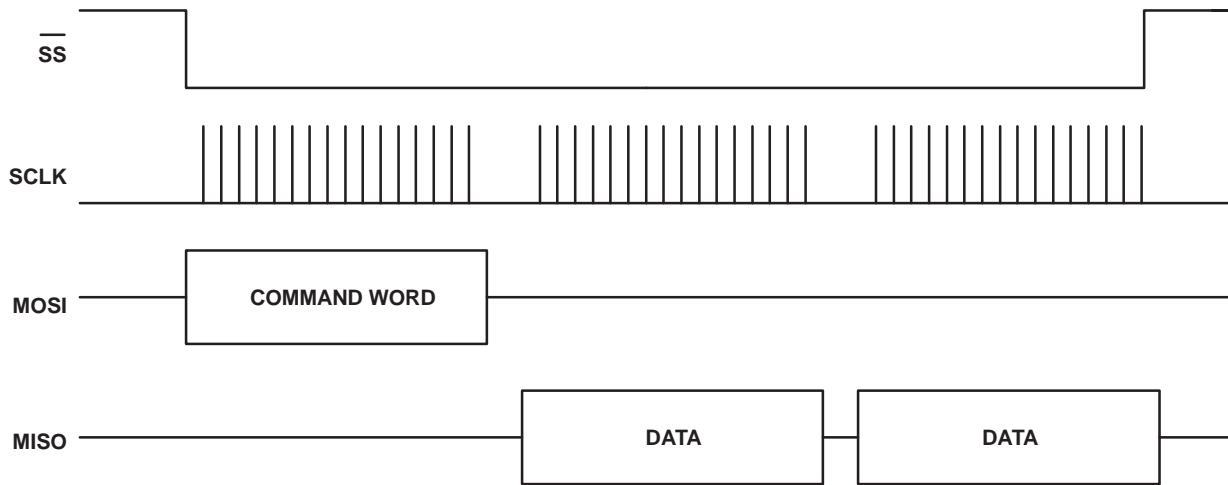

Figure 21. Read Operation for 'DAC26 SPI Interface

## 'DAC26 MEMORY MAP

The 'DAC26 has several 16-bit registers which allow control of the device as well as providing a location for results from the 'DAC26 to be stored until read by the host microprocessor. These registers are separated into three pages of memory in the 'DAC26: a data page (Page 0) and control pages (Page 1 and Page 2). The memory map is shown in Table 3.

**Table 3. Memory Map**

Page 0: Reserved		Page 1: Auxiliary Control Registers		Page 2: Audio Control Registers	
ADDR	REGISTER	ADDR	REGISTER	ADDR	REGISTER
00	Reserved	00	Reserved	00	Audio Control 1
01	Reserved	01	Reserved	01	Reserved
02	Reserved	02	Reserved	02	DAC Gain
03	Reserved	03	Reserved	03	Analog Sidetone
04	Reserved	04	Reset	04	Audio Control 2
05	Reserved	05	Reserved	05	DAC Power Control
06	Reserved	06	Reserved	06	Audio Control 3
07	Reserved	07	Reserved	07	Digital Audio Effects Filter Coefficients
08	Reserved	08	Reserved	08	Digital Audio Effects Filter Coefficients
09	Reserved	09	Reserved	09	Digital Audio Effects Filter Coefficients
0A	Reserved	0A	Reserved	0A	Digital Audio Effects Filter Coefficients
0B	Reserved	0B	Reserved	0B	Digital Audio Effects Filter Coefficients
0C	Reserved	0C	Reserved	0C	Digital Audio Effects Filter Coefficients
0D	Reserved	0D	Reserved	0D	Digital Audio Effects Filter Coefficients
0E	Reserved	0E	Reserved	0E	Digital Audio Effects Filter Coefficients
0F	Reserved	0F	Reserved	0F	Digital Audio Effects Filter Coefficients
10	Reserved	10	Reserved	10	Digital Audio Effects Filter Coefficients
11	Reserved	11	Reserved	11	Digital Audio Effects Filter Coefficients
12	Reserved	12	Reserved	12	Digital Audio Effects Filter Coefficients
13	Reserved	13	Reserved	13	Digital Audio Effects Filter Coefficients
14	Reserved	14	Reserved	14	Digital Audio Effects Filter Coefficients
15	Reserved	15	Reserved	15	Digital Audio Effects Filter Coefficients
16	Reserved	16	Reserved	16	Digital Audio Effects Filter Coefficients
17	Reserved	17	Reserved	17	Digital Audio Effects Filter Coefficients
18	Reserved	18	Reserved	18	Digital Audio Effects Filter Coefficients
19	Reserved	19	Reserved	19	Digital Audio Effects Filter Coefficients
1A	Reserved	1A	Reserved	1A	Digital Audio Effects Filter Coefficients
1B	Reserved	1B	Reserved	1B	PLL Programmability
1C	Reserved	1C	Reserved	1C	PLL Programmability
1D	Reserved	1D	Reserved	1D	Audio Control 4
1E	Reserved	1E	Reserved	1E	Audio Control 5
1F	Reserved	1F	Reserved	1F	Reserved

**'DAC26 CONTROL REGISTERS**

This section describes each of the registers shown in the memory map of Table 3. The registers are grouped according to the function they control. In the 'DAC26, bits in control registers can refer to slightly different functions depending on whether you are reading the register or writing to it.

**'DAC26 Data Registers (Page 0)**

The data registers in Page 0 are reserved.

**PAGE 1 CONTROL REGISTER MAP**

**REGISTER 00H: Reserved**

BIT	NAME	READ/ WRITE	RESET VALUE	FUNCTION
D15–D0	Reserved	R	FFFFH	Reserved

**REGISTER 01H: Reserved**

BIT	NAME	READ/ WRITE	RESET VALUE	FUNCTION
D15–D0	Reserved	R	FFFFH	Reserved

**REGISTER 02H: Reserved**

BIT	NAME	READ/ WRITE	RESET VALUE	FUNCTION
D15–D0	Reserved	R	FFFFH	Reserved

**REGISTER 03H: Reference Control**

Register 03H is reserved.

**REGISTER 04H: Reset Control**

BIT	NAME	READ/ WRITE	RESET VALUE	FUNCTION
D15–D0	RSALL	R/W	FFFFH	Reset All. Writing the code 0xBB00, as shown below, to this register causes the 'DAC26 to reset all its registers to their default, power–up values. 1011101100000000 => Reset all registers Others => Do not write other sequences to this register.

**PAGE 2 CONTROL REGISTER MAP**

**REGISTER 00H: Audio Control 1**

BIT	NAME	READ/ WRITE	RESET VALUE	FUNCTION
D15–D14		R/W	00	Reserved
D13–D12	AIN	R/W	00	Analog Input Mux 00 => Analog Input = Single-ended input MIC 01 => Analog Input = Single-ended input AUX 10 => Analog Input = Differential input MICIN and AUX 11 => Analog Input = Differential input MICIN and AUX
D11–D10	WLEN	R/W	00	DAC Word Length 00 => Word length = 16 bit 01 => Word length = 20 bit 10 => Word length = 24 bit 11 => Word length = 32 bit
D9–D8	DATFM	R/W	00	Digital Data Format 00 => I <sup>2</sup> S mode 01 => DSP mode 10 => Right justified 11 => Left justified Note: Right justified mode is NOT valid only when the DAC sampling ratio is Fsref/11.5 or Fsref/5.5
D7–D6	Reserved	R/W	00	Reserved Note: Only write a 0 to this bit
D5–D3	DACFS	R/W	000	DAC Sampling Rate 000 => DAC FS = Fsref/1 001 => DAC FS = Fsref/(1.5) 010 => DAC FS = Fsref/2 011 => DAC FS = Fsref/3 100 => DAC FS = Fsref/4 101 => DAC FS = Fsref/5 110 => DAC FS = Fsref/(5.5) 111 => DAC FS = Fsref/6 Note: Fsref can be set between 39 kHz and 53 kHz
D2–D0	Reserved	R/W	000	Reserved

**REGISTER 01H: Reserved**

BIT	NAME	READ/ WRITE	RESET VALUE	FUNCTION
D15–D0		R	FFFFH	Reserved

**REGISTER 02H: DAC Gain Control**

BIT	NAME	READ/ WRITE	RESET VALUE	FUNCTION
D15	DALMU	R/W	1	DAC Left Channel Muted 1 => DAC left channel muted 0 => DAC left channel not muted
D14–D8	DALVL	R/W	111111	DAC Left Channel Volume Control 0000000 => DAC left channel volume control = 0 dB 0000001 => DAC left channel volume control = –0.5 dB 0000010 => DAC left channel volume control = –1.0 dB ----- 1111110 => DAC left channel volume control = –63.0 dB 1111111 => DAC left channel volume control = –63.5 dB

**REGISTER 02H: DAC Gain Control (continued)**

BIT	NAME	READ/ WRITE	RESET VALUE	FUNCTION
D7	DARMU	R/W	1	DAC Right Channel Muted 1 => DAC right channel muted 0 => DAC right channel not muted
D6–D0	DARVL	R/W	1111111	DAC Right Channel Volume Control 0000000 => DAC right channel volume control = 0 dB 0000001 => DAC right channel volume control = –0.5 dB 0000010 => DAC right channel volume control = –1.0 dB ----- 1111110 => DAC right channel volume control = –63.0 dB 1111111 => DAC right channel volume control = –63.5 dB

**REGISTER 03H: Analog Sidetone Control**

BIT	NAME	READ/ WRITE	RESET VALUE	FUNCTION
D15	ASTMU	R/W	1	Analog Sidetone Mute Control 1 => Analog sidetone muted 0 => Analog sidetone not muted
D14–D8	ASTG	R/W	1000101	Analog Sidetone Gain Setting 0000000 => Analog sidetone gain setting = –34.5 dB 0000001 => Analog sidetone gain setting = –34 dB 0000010 => Analog sidetone gain setting = –33.5 dB ----- 1000101 => Analog sidetone gain setting = 0 dB 1000110 => Analog sidetone gain setting = 0.5 dB ----- 1011100 => Analog sidetone gain setting = 11.5 dB 1011101 => Analog sidetone gain setting = 12 dB 1011110 => Analog sidetone gain setting = 12 dB 1011111 => Analog sidetone gain setting = 12 dB ----- 11xxxxx => Analog sidetone gain setting = 12 dB
D7–D1	Reserved	R/W	1	Reserved Note: Only write a 1 to this bit
D0	ASTGF	R	0	Analog Sidetone PGA Flag ( Read Only ) 0 => Gain applied != PGA register setting 1 => PGA applied = PGA register setting. Note: Analog sidetone gain is implemented at zero crossings of the signal.

**REGISTER 04H: Audio Control 2**

BIT	NAME	READ/ WRITE	RESET VALUE	FUNCTION
D15	KCLLEN	R/W	0	Keyclick Enable 0 => Keyclick disabled 1 => Keyclick enabled Note: This bit is automatically cleared after giving out the keyclick signal length equal to the programmed value.
D14–D12	KCLAC	R/W	100	Keyclick Amplitude Control 000 => Lowest amplitude 100 => Medium amplitude 111 => Highest amplitude
D11	Reserved	R/W	0	Reserved Note: Only write a 0 to this bit
D10–D8	KCLFRQ	R/W	100	Keyclick Frequency 000 => 62.5 Hz 001 => 125 Hz 010 => 250 Hz 011 => 500 Hz 100 => 1 kHz 101 => 2 kHz 110 => 4 kHz 111 => 8 kHz
D7–D4	KCLLN	R/W	0001	Keyclick Length 0000 => 2 periods key click 0001 => 4 periods key click 0010 => 6 periods key click ----- 1110 => 30 periods key click 1111 => 32 periods key click
D3	DLGAF	R	0	DAC Left Channel PGA Flag ( Read Only ) 0 => Gain applied != PGA register setting 1 => Gain applied = PGA register setting Note: This flag indicates when the soft-stepping for DAC left channel is completed
D2	DRGAF	R	0	DAC Right Channel PGA Flag ( Read Only ) 0 => Gain applied != PGA register setting 1 => Gain applied = PGA register setting Note: This flag indicates when the soft-stepping for DAC right channel is completed
D1	DASTC	R/W	0	DAC Channel PGA Soft-Stepping Control 0 => 0.5dB change every LRCK 1 => 0.5dB change every 2 LRCK
D0	Reserved	R/W	0	Reserved Note: Only write a 0 to this bit

**REGISTER 05H: DAC Power Control**

BIT	NAME	READ/ WRITE	RESET VALUE	FUNCTION
D15	PWDNC	R/W	1	DAC Power-Down Control 0 => DAC powered up 1 => DAC powered down
D14	Reserved	R/W	0	Reserved (During read the value of this bit is 0. Write only 0 into this location.) Note: Only set this bit to the reset value 0 or 1
D13	ASTPWD	R/W	1	Analog Sidetone Power-down Control 0 => Analog sidetone powered up 1 => Analog sidetone powered down
D12	DAODRC	R/W	0	Audio Output Driver Control 0 => Output driver in low power mode 1 => Output driver in high power mode
D11	ASTPWF	R	1	Analog Sidetone Power-Down Flag 0 => Analog sidetone powered down is not complete. 1 => Analog sidetone powered down is complete.
D10	DAPWDN	R/W	1	DAC Power-Down Control 0 => Power up the DAC 1 => Power down the DAC
D9	Reserved	R/W	1	Reserved Note: Only set this bit to the reset value 0 or 1
D8	VGPWDN	R/W	1	Driver Virtual Ground Power Down 0 => Power up the VGND amp 1 => Power down the VGND amp
D7	Reserved	R/W	1	Reserved Note: Only set this bit to the reset value 0 or 1
D6	DAPWDF	R	1	DAC Power-Down Flag (See DAC Power down section of this data sheet) 0 => DAC power down is not complete. 1 => DAC power down is complete.
D5	Reserved	R/W	0	Reserved Note: Only set this bit to the reset value 0 or 1
D4	VBIAS	R/W	0	VBIAS Voltage 0 => VBIAS output = 2.5 V 1 => VBIAS output = 2.0 V
D3–D2	Reserved	R/W	0	Reserved Note: Only set this bit to the reset value 0 or 1
D1	EFFCTL	R/W	0	Digital Audio Effects Filter Control 0 => Disable digital audio effects filter 1 => Enable digital audio effects filter
D0	DEEMPF	R/W	0	De–Emphasis Filter Enable 0 => Disable de-emphasis filter 1 => Enable de-emphasis filter



**REGISTER 06H: Audio Control 3**

BIT	NAME	READ/ WRITE	RESET VALUE	FUNCTION
D15–D14	DMSVOL	R/W	00	DAC Channel Master Volume Control 00 => Left channel and right channel have independent volume controls 01 => Left channel volume control is the programmed value of the right channel volume control. 10 => Right channel volume control is the programmed value of the left channel volume control. 11 => same as 00
D13	REFFS	R/W	0	Reference Sampling Rate. This setting controls the coefficients in the de-emphasis filter. If an Fsref above 48 kHz is being used, then it is recommended to set this to the 48-kHz setting, otherwise either setting can be used. 0 => Fsref = 48.0 kHz 1 => Fsref = 44.1 kHz
D12	DAXFM	R/W	0	Master Transfer Mode 0 => Continuous data transfer mode 1 => 256–s data transfer mode
D11	SLVMS	R/W	0	DAC Master Slave Control 0 => 'DAC26 is slave 1 => 'DAC26 is master
D10–D9	DAPK2PK	R/W	00	DAC Max Output Signal Swing and Common Mode Voltage 00 => DAC max output signal swing = 2.0 V, $V_{CM} = 1.35$ V 01 => DAC max output signal swing = 2.192 V (only recommended for analog supply of 3.0 V and digital supply of 1.65 V and above), $V_{CM} = 1.48$ V 10 => DAC max output signal swing = 2.402 V (only recommended for analog supply of 3.3 V and digital supply of 1.8 V and above), $V_{CM} = 1.62$ V 11 => DAC max output signal swing = 2.633 V (only recommended for analog supply of 3.6 V and digital supply of 1.95 V), $V_{CM} = 1.78$ V
D8	Reserved	R/W	0	Reserved Note: Always write the reset value to this bit
D7	DALOVF	R	0	DAC Left Channel Overflow Flag ( Read Only ) 0 => DAC left channel data is within saturation limits. 1 => DAC left channel data has exceeded saturation limits. Note : This flag is reset only on register read.
D6	DAROVF	R	0	DAC Right Channel Overflow Flag ( Read Only ) 0 => DAC right channel data is within saturation limits. 1 => DAC right channel data has exceeded saturation limits. Note : This flag is reset only on register read.
D5–D0	Reserved	R/W	0	Reserved Note: Always write the reset value to this bit

**REGISTER 07H: Digital Audio Effects Filter Coefficients**

BIT	NAME	READ/ WRITE	RESET VALUE (IN DECIMAL)	FUNCTION
D15–D0	L_N0	R/W	27619	Left channel digital audio effects filter coefficient N0

**REGISTER 08H: Digital Audio Effects Filter Coefficients**

BIT	NAME	READ/ WRITE	RESET VALUE (IN DECIMAL)	FUNCTION
D15–D0	L_N1	R/W	–27034	Left channel digital audio effects filter coefficient N1

**REGISTER 09H: Digital Audio Effects Filter Coefficients**

BIT	NAME	READ/ WRITE	RESET VALUE (IN DECIMAL)	FUNCTION
D15–D0	L_N2	R/W	26461	Left channel digital audio effects filter coefficient N2

**REGISTER 0AH: Digital Audio Effects Filter Coefficients**

BIT	NAME	READ/ WRITE	RESET VALUE (IN DECIMAL)	FUNCTION
D15–D0	L_N3	R/W	27619	Left channel digital audio effects filter coefficient N3

**REGISTER 0BH: Digital Audio Effects Filter Coefficients**

BIT	NAME	READ/ WRITE	RESET VALUE (IN DECIMAL)	FUNCTION
D15–D0	L_N4	R/W	–27034	Left channel digital audio effects filter coefficient N4

**REGISTER 0CH: Digital Audio Effects Filter Coefficients**

BIT	NAME	READ/ WRITE	RESET VALUE (IN DECIMAL)	FUNCTION
D15–D0	L_N5	R/W	26461	Left channel digital audio effects filter coefficient N5

**REGISTER 0DH: Digital Audio Effects Filter Coefficients**

BIT	NAME	READ/ WRITE	RESET VALUE (IN DECIMAL)	FUNCTION
D15–D0	L_D1	R/W	32131	Left channel digital audio effects filter coefficient D1

**REGISTER 0EH: Digital Audio Effects Filter Coefficients**

BIT	NAME	READ/ WRITE	RESET VALUE (IN DECIMAL)	FUNCTION
D15–D0	L_D2	R/W	–31506	Left channel digital audio effects filter coefficient D2

**REGISTER 0FH: Digital Audio Effects Filter Coefficients**

BIT	NAME	READ/ WRITE	RESET VALUE (IN DECIMAL)	FUNCTION
D15–D0	L_D4	R/W	32131	Left channel digital audio effects filter coefficient D4

**REGISTER 10H: Digital Audio Effects Filter Coefficients**

BIT	NAME	READ/ WRITE	RESET VALUE (IN DECIMAL)	FUNCTION
D15–D0	L_D5	R/W	–31506	Left channel digital audio effects filter coefficient D5

**REGISTER 11H: Digital Audio Effects Filter Coefficients**

BIT	NAME	READ/ WRITE	RESET VALUE (IN DECIMAL)	FUNCTION
D15–D0	R_N0	R/W	27619	Right channel digital audio effects filter coefficient N0

**REGISTER 12H: Digital Audio Effects Filter Coefficients**

BIT	NAME	READ/ WRITE	RESET VALUE (IN DECIMAL)	FUNCTION
D15–D0	R_N1	R/W	–27034	Right channel digital audio effects filter coefficient N1

**REGISTER 13H: Digital Audio Effects Filter Coefficients**

BIT	NAME	READ/ WRITE	RESET VALUE (IN DECIMAL)	FUNCTION
D15–D0	R_N2	R/W	26461	Right channel digital audio effects filter coefficient N2

**REGISTER 14H: Digital Audio Effects Filter Coefficients**

BIT	NAME	READ/ WRITE	RESET VALUE (IN DECIMAL)	FUNCTION
D15–D0	R_N3	R/W	27619	Right channel digital audio effects filter coefficient N3

**REGISTER 15H: Digital Audio Effects Filter Coefficients**

BIT	NAME	READ/ WRITE	RESET VALUE (IN DECIMAL)	FUNCTION
D15–D0	R_N4	R/W	–27034	Right channel digital audio effects filter coefficient N4

**REGISTER 16H: Digital Audio Effects Filter Coefficients**

BIT	NAME	READ/ WRITE	RESET VALUE (IN DECIMAL)	FUNCTION
D15–D0	R_N5	R/W	26461	Right channel digital audio effects filter coefficient N5

**REGISTER 17H: Digital Audio Effects Filter Coefficients**

BIT	NAME	READ/ WRITE	RESET VALUE (IN DECIMAL)	FUNCTION
D15–D0	R_D1	R/W	32131	Right channel digital audio effects filter coefficient D1

**REGISTER 18H: Digital Audio Effects Filter Coefficients**

BIT	NAME	READ/ WRITE	RESET VALUE (IN DECIMAL)	FUNCTION
D15–D0	R_D2	R/W	–31506	Right channel digital audio effects filter coefficient D2

**REGISTER 19H: Digital Audio Effects Filter Coefficients**

BIT	NAME	READ/ WRITE	RESET VALUE (IN DECIMAL)	FUNCTION
D15–D0	R_D4	R/W	32131	Right channel digital audio effects filter coefficient D4

**REGISTER 1AH: Digital Audio Effects Filter Coefficients**

BIT	NAME	READ/ WRITE	RESET VALUE (IN DECIMAL)	FUNCTION
D15–D0	R_D5	R/W	–31506	Right channel digital audio effects filter coefficient D5

**REGISTER 1BH: PLL Programmability**

BIT	NAME	READ/ WRITE	RESET VALUE	FUNCTION
D15	PLLSEL	R/W	0	PLL Enable 0 => Disable PLL 1 => Enable PLL
D14–D11	QVAL	R/W	0010	Q value. Valid only if PLL is disabled. 0000 => 16 0001 => 17 0010 => 2 0011 => 3 ----- 1100 => 12 1101 => 13 1110 => 14 1111 => 15
D10–D8	PVAL	R/W	000	P value. Valid when PLL is enabled 000 => 8 001 => 1 010 => 2 011 => 3 100 => 4 101 => 5 110 => 6 111 => 7
D7–D2	JVAL	R/W	000001	J value. Valid only if PLL is enabled. 000000 => Not valid 000001 => 1 000010 => 2 ----- 111110 => 62 111111 => 63
D1–D0	Reserved	R	00	Reserved (write only 00)

**REGISTER 1CH: PLL Programmability**

BIT	NAME	READ/ WRITE	RESET VALUE	FUNCTION
D15–D2	DVAL	R/W	0 (in decimal)	D value. Used when PLL is enabled. D value is valid from 0000 to 9999 in decimal. Programmed value greater than 9999 is treated as 9999. 00000000000000 => 0 decimal 00000000000001 => 1 decimal
D1–D0	Reserved	R	00	Reserved (write only 00)

**REGISTER 1DH: Audio Control 4**

BIT	NAME	READ/ WRITE	RESET VALUE	FUNCTION
D15		R/W	0	Reserved
D14	DASTPD	R/W	0	DAC PGA Soft-Stepping Control 0 => Soft-stepping enabled 1 => Soft-stepping disabled
D13	ASSTPD	R/W	0	Analog Sidetone Soft-Stepping Control 0 => Soft-stepping enabled 1 => Soft-stepping disabled
D12–D9	Reserved	R/W	0	Reserved Note: Only write a 0 to this bit
D8	SHCKT_DIS	R/W	0	Disable Short Circuit Detection 0 => Short circuit detection enabled 1 => Short circuit detection disabled
D7	SHCKT_PD	R/W	0	Power Down Drivers if Short Circuit Detected 0 => No auto power down of drivers on short circuit. 1 => Auto power down drivers on short circuit.
D6	SHCKT_FLAG	R	0	Short Circuit Detected Flag 0 => Short circuit not detected 1 => Short circuit detected
D5	DAC_POP_RED	R	0	DAC POP Reduction Enable 0 => Disable POP reduction 1 => Enable POP reduction
D4	DAC_POP_RED_SET1	R/W	0	DAC POP Reduction Setting 1 0 => Fast setting 1 => Slow setting
D3–D2	DAC_POP_RED_SET2	R/W	00	DAC POP Reduction Setting 2 00 => Long setting 11 => Short setting
D1–D0	Reserved	R	XX	Reserved

**REGISTER 1EH: Audio Control 5**

BIT	NAME	READ/ WRITE	RESET VALUE	FUNCTION
D15–D3	Reserved	R/W	0	Reserved Note: Only write a 0 to this bit
D2	DRV_POP_DIS	R/W	0	Audio Output Driver POP Reduction Enable 0 => Enabled 1 => Disabled
D1	DRV_POP_LEN	R/W	0	Audio Output Driver POP Reduction Duration 0 => Output driver ramps to final voltage in approximately 0.8 sec, if VGND is powered down (1 msec otherwise). 1 => Output driver ramps to final voltage in approximately 4 sec, if VGND is powered down (1 msec otherwise).
D0	Reserved	R	0	Reserved. Always write a 0 to this bit.

## LAYOUT

The following layout suggestions should provide optimum performance from the 'DAC26. However, many portable applications have conflicting requirements concerning power, cost, size, and weight. In general, most portable devices have fairly *clean* power and grounds because most of the internal components are very low power. This situation means less bypassing for the converter power and less concern regarding grounding. Still, each situation is unique and the following suggestions should be reviewed carefully.

For optimum performance, care must be taken with the physical layout of the 'DAC26 circuitry. Power to the 'DAC26 must be clean and well bypassed. A 0.1- $\mu$ F ceramic bypass capacitor must be placed as close to the device as possible. A 1- $\mu$ F to 10- $\mu$ F capacitor may also be needed if the impedance between the 'DAC26 supply pins and the system power supply is high.

The ground pins must be connected to a clean ground point. In many cases, this is the *analog* ground. Avoid connections which are too near the grounding point of a microcontroller or digital signal processor. If needed, run a ground trace directly from the converter to the power supply entry or battery connection point. The ideal layout includes an analog ground plane dedicated to the converter and associated analog circuitry.

## DAC CHANNEL DIGITAL FILTER

### DAC Channel Digital Filter Frequency Response

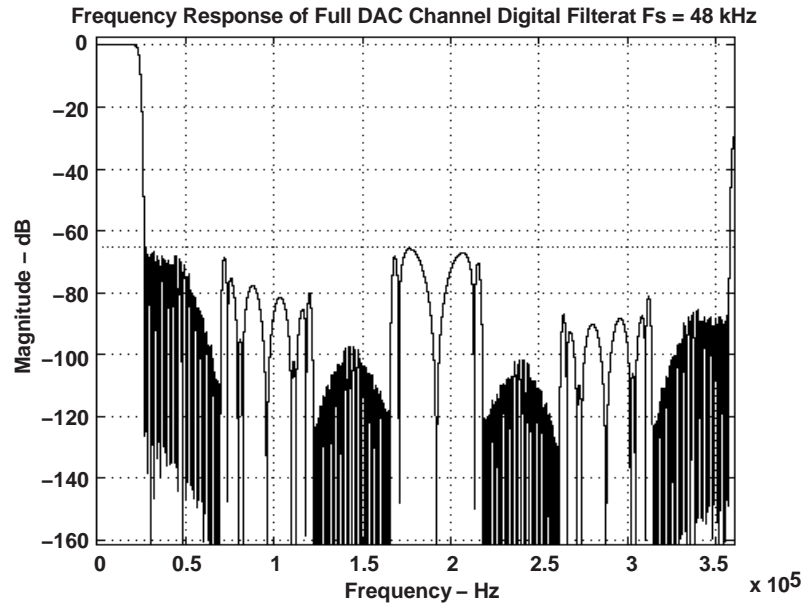

### DAC Channel Digital Filter Pass-Band Frequency Response

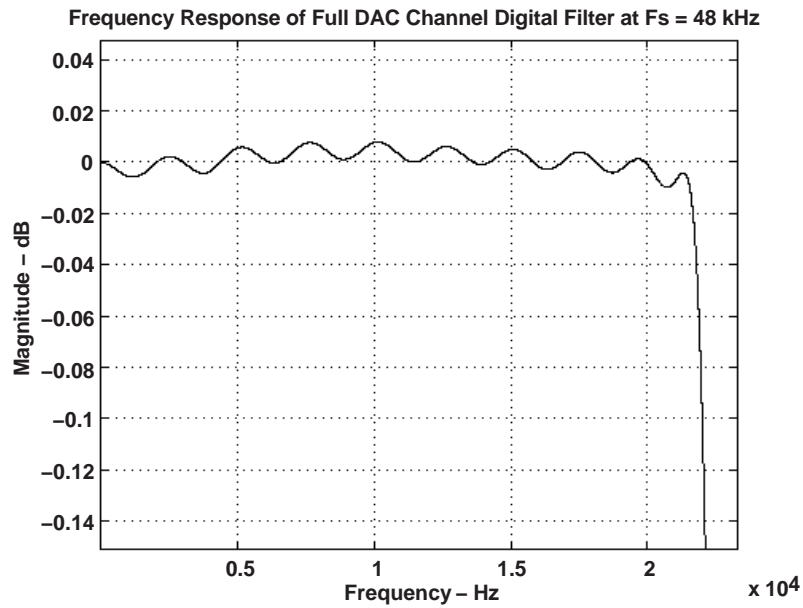

**DEFAULT DIGITAL AUDIO EFFECTS FILTER RESPONSE AT 48 kbps**

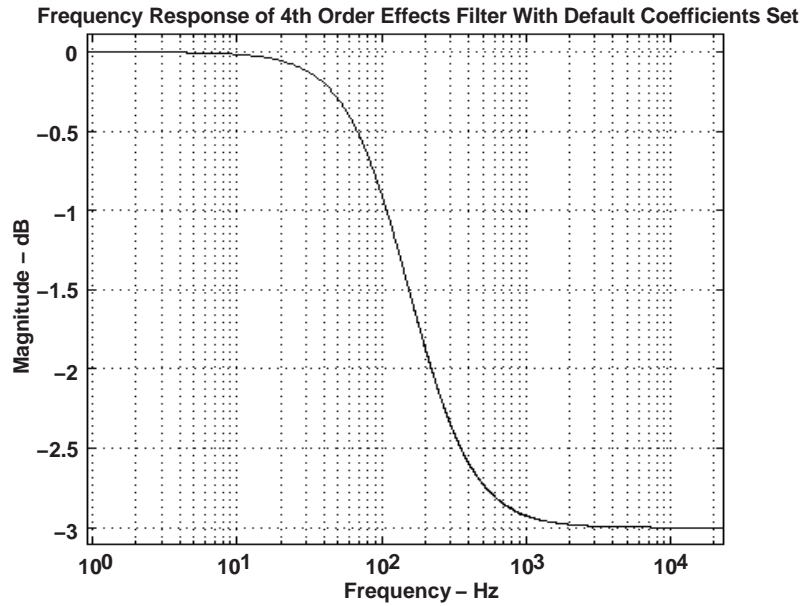

**DE-EMPHASIS FILTER FREQUENCY RESPONSE**

**De-Emphasis Filter Response at 32 kbps**

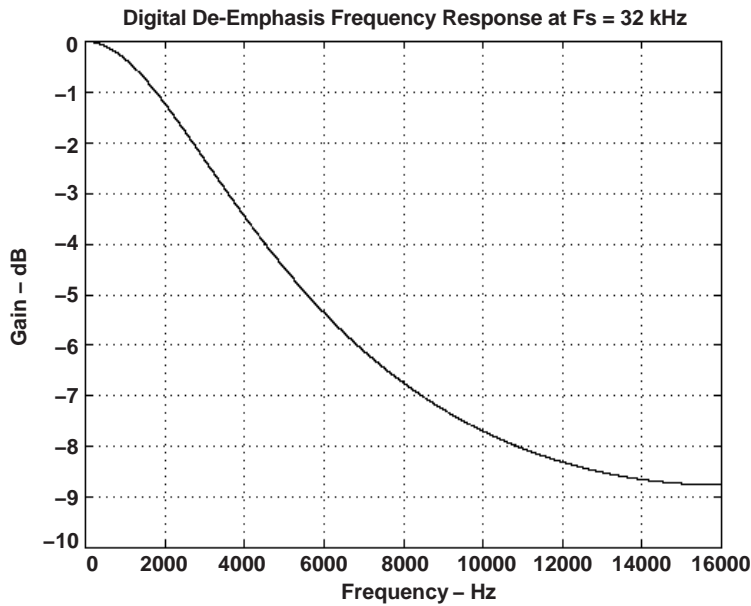



**De-Emphasis Error at 32 kbps**

De-Emphasis Error With Respect to Ideal Frequency Response For  $F_s = 33$  kHz

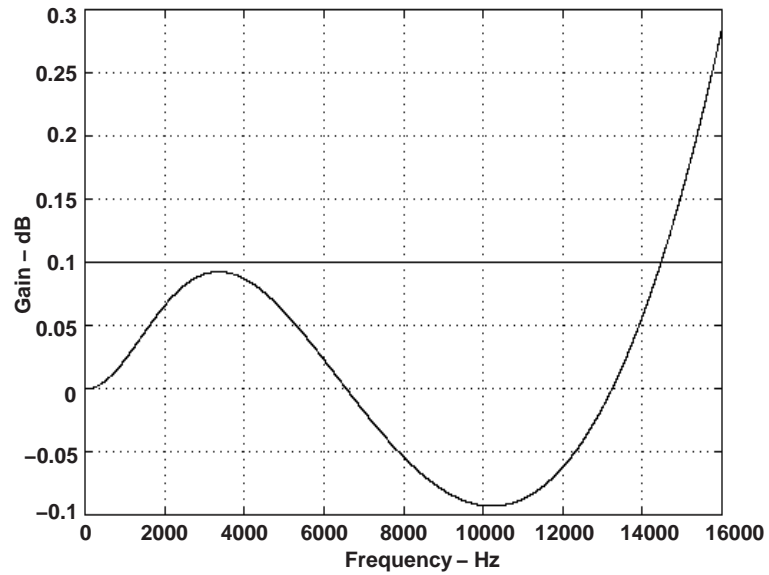

**De-Emphasis Filter Frequency Response at 44.1 kbps**

Digital De-Emphasis Frequency Response For  $F_s = 44.1$  kHz

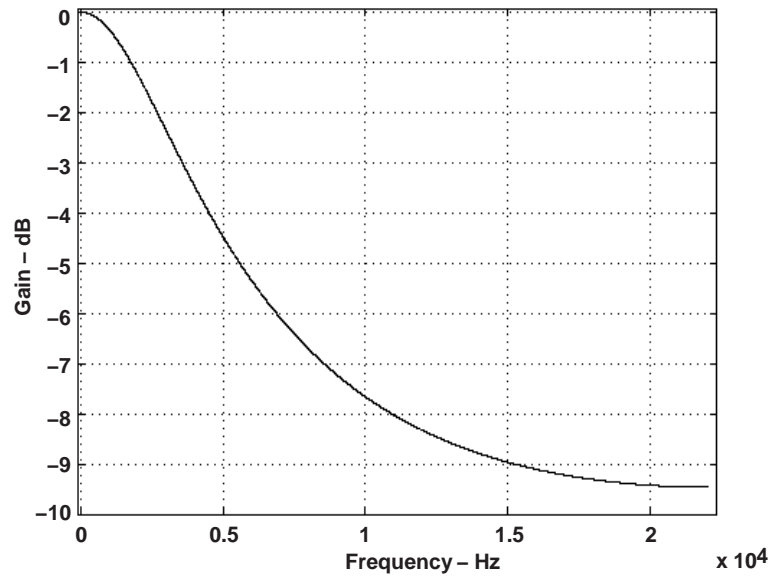

De-Emphasis Error at 44.1 kps

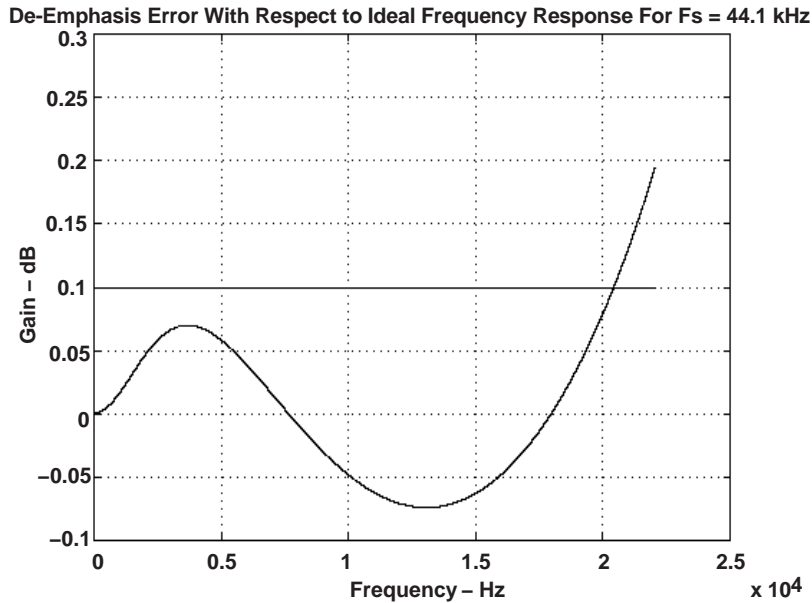

De-Emphasis Frequency Response at 48 kps

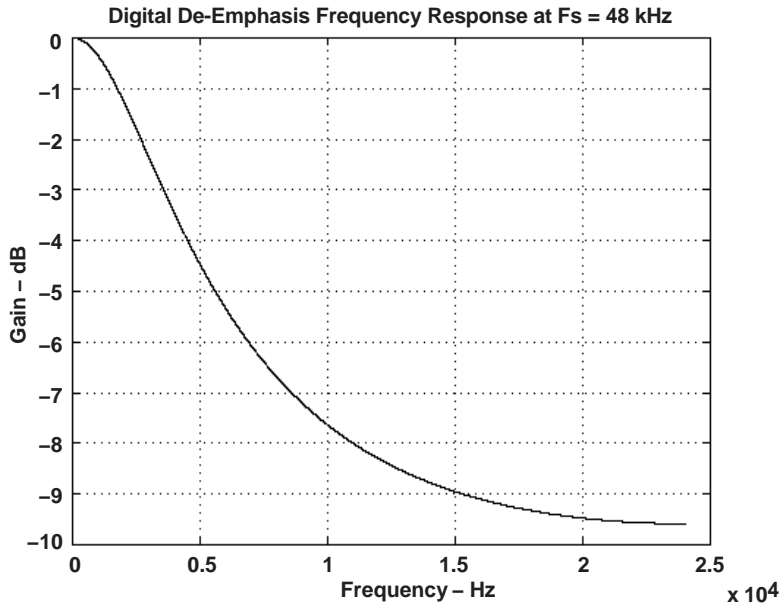

**De-Emphasis Error at 48 ksp/s**

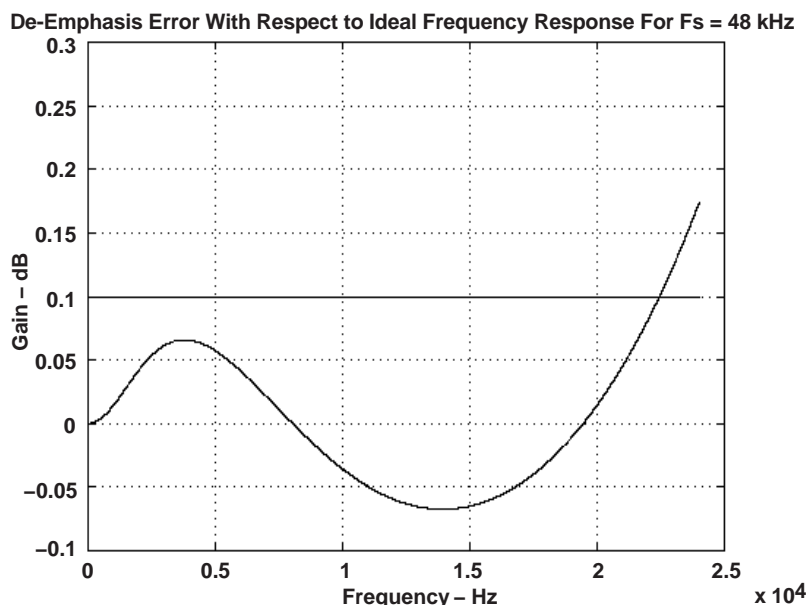

**PLL PROGRAMMING**

The on-chip PLL in the 'DAC26 can be used to generate sampling clocks from a wide range of MCLK's available in a system. The PLL works by generating oversampled clocks with respect to  $F_{sref}$  (44.1 kHz or 48 kHz). Frequency division generates all other internal clocks. The table below gives a sample programming for PLL registers for some standard MCLK's when PLL is required. Whenever the MCLK is of the form of  $N \times 128 \times F_{sref}$  ( $N=2,3,\dots,17$ ), PLL is not required.

**$F_{sref} = 44.1$  kHz**

MCLK (MHz)	P	J	D	ACHIEVED FSREF	% ERROR
2.8224	1	32	0	44100.00	0.0000
5.6448	1	16	0	44100.00	0.0000
12	1	7	5264	44100.00	0.0000
13	1	6	9474	44099.71	0.0007
16	1	5	6448	44100.00	0.0000
19.2	1	4	7040	44100.00	0.0000
19.68	1	4	5893	44100.30	-0.0007
48	4	7	5264	44100.00	0.0000

**$F_{sref} = 48$  kHz**

MCLK (MHz)	P	J	D	ACHIEVED FSREF	% ERROR
2.048	1	48	0	48000.00	0.0000
3.072	1	32	0	48000.00	0.0000
4.096	1	24	0	48000.00	0.0000
6.144	1	16	0	48000.00	0.0000
8.192	1	12	0	48000.00	0.0000
12	1	8	1920	48000.00	0.0000
13	1	7	5618	47999.71	0.0006
16	1	6	1440	48000.00	0.0000
19.2	1	5	1200	48000.00	0.0000
19.68	1	4	9951	47999.79	0.0004
48	4	8	1920	48000.00	0.0000

**PACKAGING INFORMATION**

Orderable Device	Status <sup>(1)</sup>	Package Type	Package Drawing	Pins	Package Qty	Eco Plan <sup>(2)</sup>	Lead/Ball Finish	MSL Peak Temp <sup>(3)</sup>
TLV320DA26IRHBG4	ACTIVE	QFN	RHB	32	73	Green (RoHS & no Sb/Br)	CU NIPDAU	Level-2-260C-1 YEAR
TLV320DAC26IRHB	ACTIVE	QFN	RHB	32	73	Green (RoHS & no Sb/Br)	CU NIPDAU	Level-2-260C-1 YEAR
TLV320DAC26IRHBG4	ACTIVE	QFN	RHB	32	73	Green (RoHS & no Sb/Br)	CU NIPDAU	Level-2-260C-1 YEAR
TLV320DAC26IRHBR	ACTIVE	QFN	RHB	32	3000	Green (RoHS & no Sb/Br)	CU NIPDAU	Level-2-260C-1 YEAR
TLV320DAC26IRHBG4	ACTIVE	QFN	RHB	32	3000	Green (RoHS & no Sb/Br)	CU NIPDAU	Level-2-260C-1 YEAR

<sup>(1)</sup> The marketing status values are defined as follows:

**ACTIVE:** Product device recommended for new designs.

**LIFEBUY:** TI has announced that the device will be discontinued, and a lifetime-buy period is in effect.

**NRND:** Not recommended for new designs. Device is in production to support existing customers, but TI does not recommend using this part in a new design.

**PREVIEW:** Device has been announced but is not in production. Samples may or may not be available.

**OBSOLETE:** TI has discontinued the production of the device.

<sup>(2)</sup> Eco Plan - The planned eco-friendly classification: Pb-Free (RoHS), Pb-Free (RoHS Exempt), or Green (RoHS & no Sb/Br) - please check <http://www.ti.com/productcontent> for the latest availability information and additional product content details.

**TBD:** The Pb-Free/Green conversion plan has not been defined.

**Pb-Free (RoHS):** TI's terms "Lead-Free" or "Pb-Free" mean semiconductor products that are compatible with the current RoHS requirements for all 6 substances, including the requirement that lead not exceed 0.1% by weight in homogeneous materials. Where designed to be soldered at high temperatures, TI Pb-Free products are suitable for use in specified lead-free processes.

**Pb-Free (RoHS Exempt):** This component has a RoHS exemption for either 1) lead-based flip-chip solder bumps used between the die and package, or 2) lead-based die adhesive used between the die and leadframe. The component is otherwise considered Pb-Free (RoHS compatible) as defined above.

**Green (RoHS & no Sb/Br):** TI defines "Green" to mean Pb-Free (RoHS compatible), and free of Bromine (Br) and Antimony (Sb) based flame retardants (Br or Sb do not exceed 0.1% by weight in homogeneous material)

<sup>(3)</sup> MSL, Peak Temp. -- The Moisture Sensitivity Level rating according to the JEDEC industry standard classifications, and peak solder temperature.

**Important Information and Disclaimer:**The information provided on this page represents TI's knowledge and belief as of the date that it is provided. TI bases its knowledge and belief on information provided by third parties, and makes no representation or warranty as to the accuracy of such information. Efforts are underway to better integrate information from third parties. TI has taken and continues to take reasonable steps to provide representative and accurate information but may not have conducted destructive testing or chemical analysis on incoming materials and chemicals. TI and TI suppliers consider certain information to be proprietary, and thus CAS numbers and other limited information may not be available for release.

In no event shall TI's liability arising out of such information exceed the total purchase price of the TI part(s) at issue in this document sold by TI to Customer on an annual basis.

**TAPE AND REEL INFORMATION**



**QUADRANT ASSIGNMENTS FOR PIN 1 ORIENTATION IN TAPE**



\*All dimensions are nominal

Device	Package Type	Package Drawing	Pins	SPQ	Reel Diameter (mm)	Reel Width W1 (mm)	A0 (mm)	B0 (mm)	K0 (mm)	P1 (mm)	W (mm)	Pin1 Quadrant
TLV320DAC26IRHBR	QFN	RHB	32	3000	330.0	12.4	5.3	5.3	1.5	8.0	12.0	Q2

**TAPE AND REEL BOX DIMENSIONS**



\*All dimensions are nominal

Device	Package Type	Package Drawing	Pins	SPQ	Length (mm)	Width (mm)	Height (mm)
TLV320DAC261RHBR	QFN	RHB	32	3000	340.5	333.0	20.6

RHB (S-PQFP-N32)

PLASTIC QUAD FLATPACK

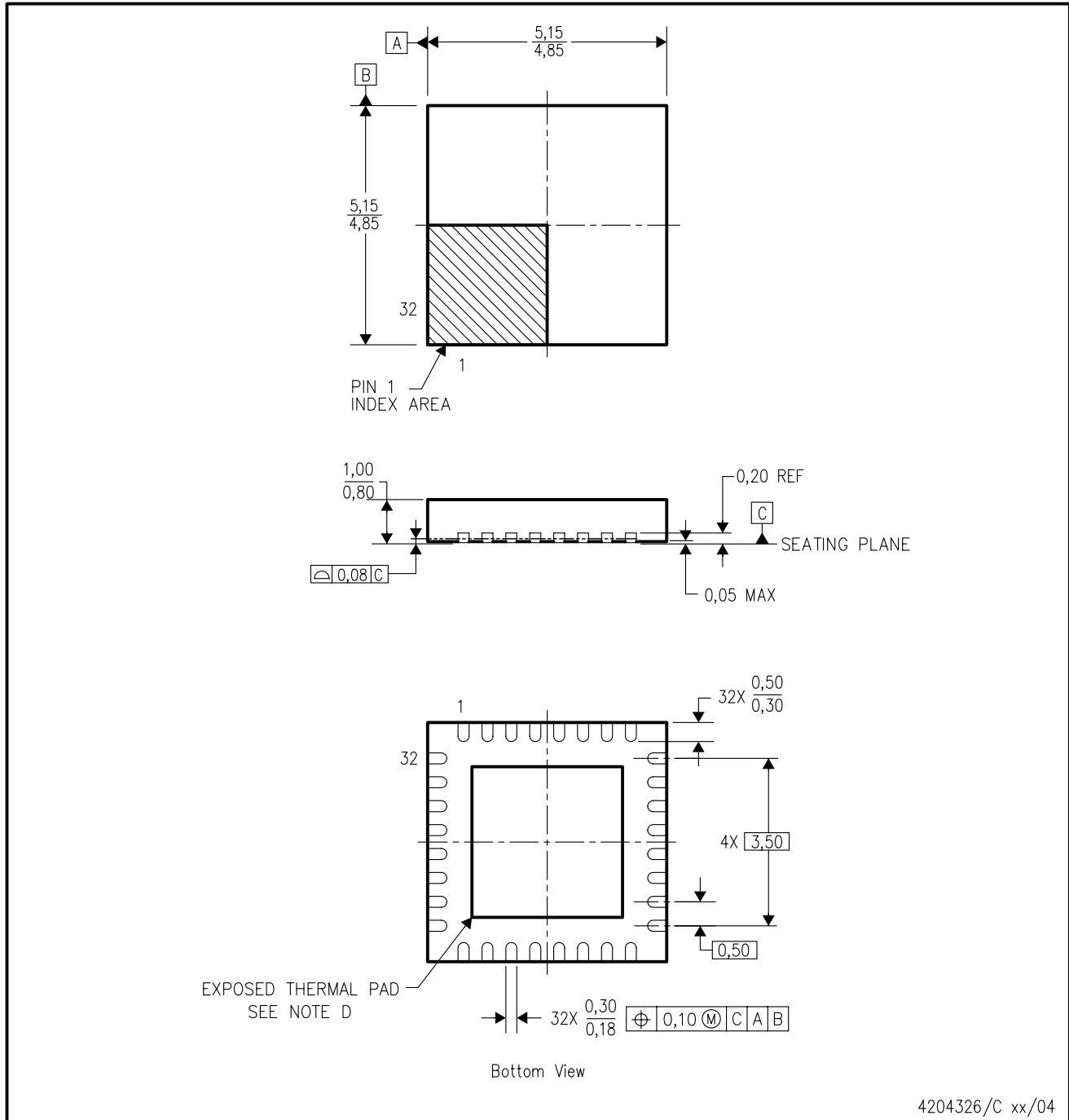

4204326/C xx/04

- NOTES:
- All linear dimensions are in millimeters.
  - This drawing is subject to change without notice.
  - QFN (Quad Flatpack No-Lead) Package configuration.
  - The Package thermal pad must be soldered to the board for thermal and mechanical performance. See product data sheet for details regarding the exposed thermal pad dimensions.
  - Falls within JEDEC MO-220.

THERMAL INFORMATION

This package incorporates an exposed thermal pad that is designed to be attached directly to an external heatsink. The thermal pad must be soldered directly to the printed circuit board (PCB). After soldering, the PCB can be used as a heatsink. In addition, through the use of thermal vias, the thermal pad can be attached directly to the appropriate copper plane shown in the electrical schematic for the device, or alternatively, can be attached to a special heatsink structure designed into the PCB. This design optimizes the heat transfer from the integrated circuit (IC).

For information on the Quad Flatpack No-Lead (QFN) package and its advantages, refer to Application Report, QFN/SON PCB Attachment, Texas Instruments Literature No. SLUA271. This document is available at www.ti.com.

The exposed thermal pad dimensions for this package are shown in the following illustration.

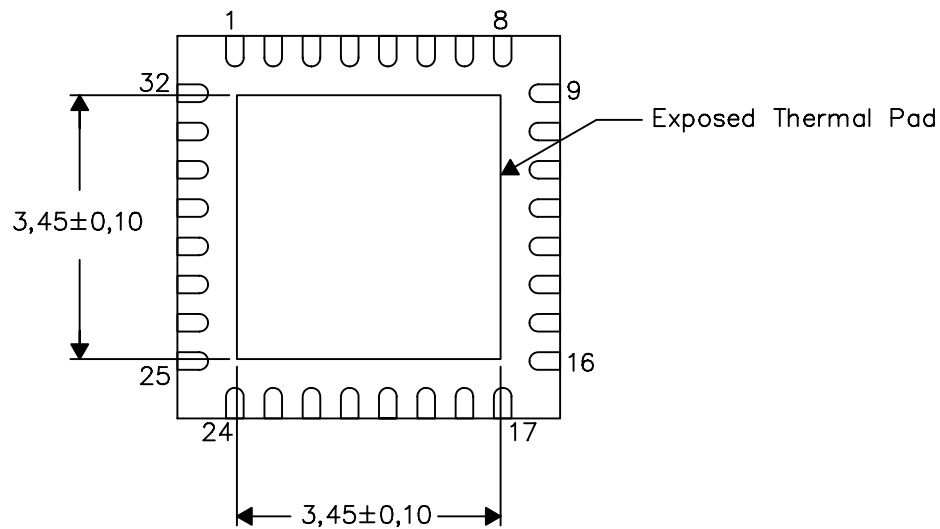

Bottom View

NOTE: All linear dimensions are in millimeters

Exposed Thermal Pad Dimensions



RHB (S-PQFP-N32)

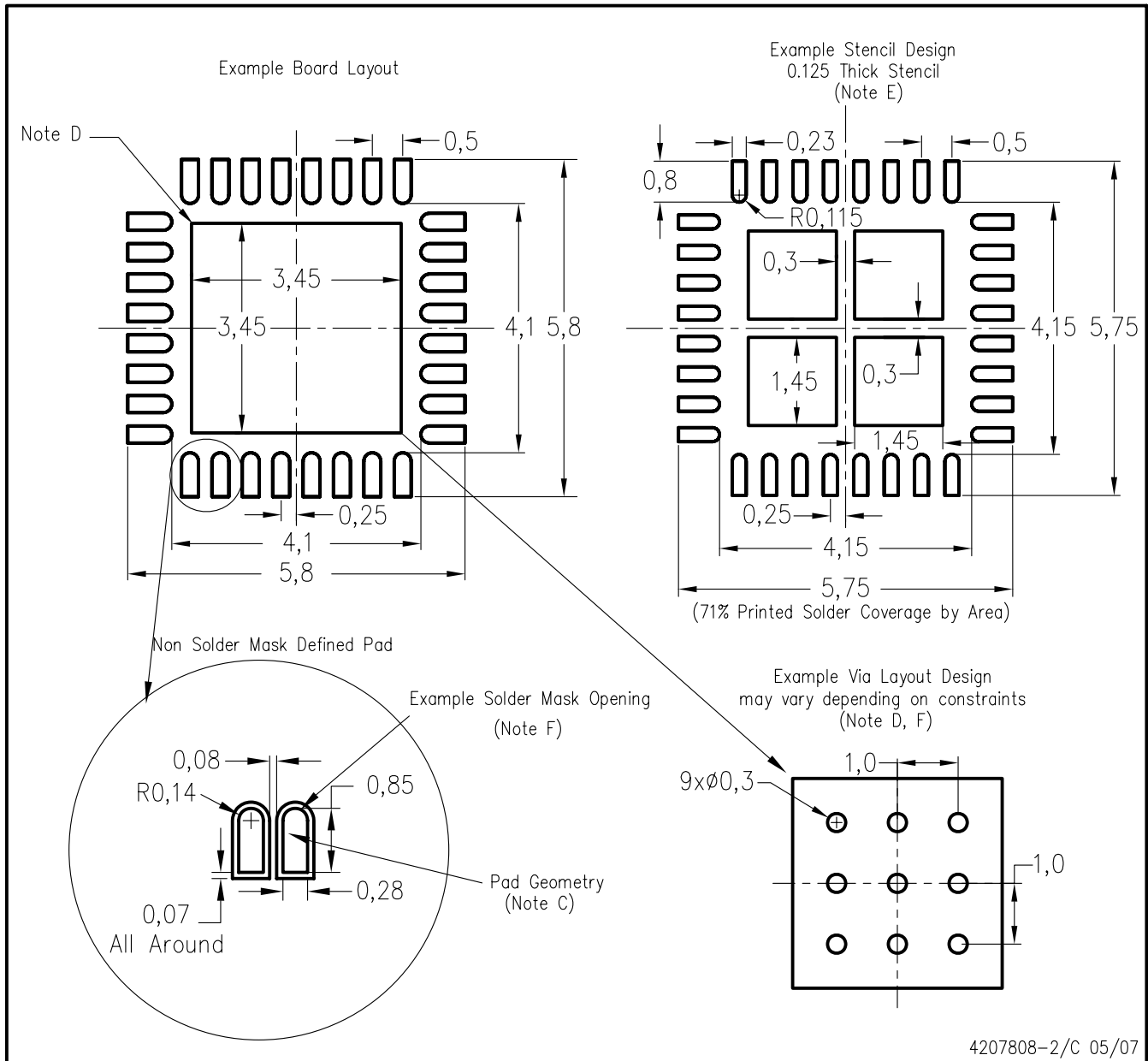

- NOTES:
- All linear dimensions are in millimeters.
  - This drawing is subject to change without notice.
  - Publication IPC-7351 is recommended for alternate designs.
  - This package is designed to be soldered to a thermal pad on the board. Refer to Application Note, Quad Flat-Pack Packages, Texas Instruments Literature No. SCBA017, SLUA271, and also the Product Data Sheets for specific thermal information, via requirements, and recommended board layout. These documents are available at [www.ti.com](http://www.ti.com) <<http://www.ti.com>>.
  - Laser cutting apertures with trapezoidal walls and also rounding corners will offer better paste release. Customers should contact their board assembly site for stencil design recommendations. Refer to IPC 7525 for stencil design considerations.
  - Customers should contact their board fabrication site for recommended solder mask tolerances and via tenting recommendations for vias placed in the thermal pad.

**THERMAL INFORMATION**

This package incorporates an exposed thermal pad that is designed to be attached directly to an external heatsink. The thermal pad must be soldered directly to the printed circuit board (PCB). After soldering, the PCB can be used as a heatsink. In addition, through the use of thermal vias, the thermal pad can be attached directly to the appropriate copper plane shown in the electrical schematic for the device, or alternatively, can be attached to a special heatsink structure designed into the PCB. This design optimizes the heat transfer from the integrated circuit (IC).

For information on the Quad Flatpack No-Lead (QFN) package and its advantages, refer to Application Report, QFN/SON PCB Attachment, Texas Instruments Literature No. SLUA271. This document is available at [www.ti.com](http://www.ti.com).

The exposed thermal pad dimensions for this package are shown in the following illustration.

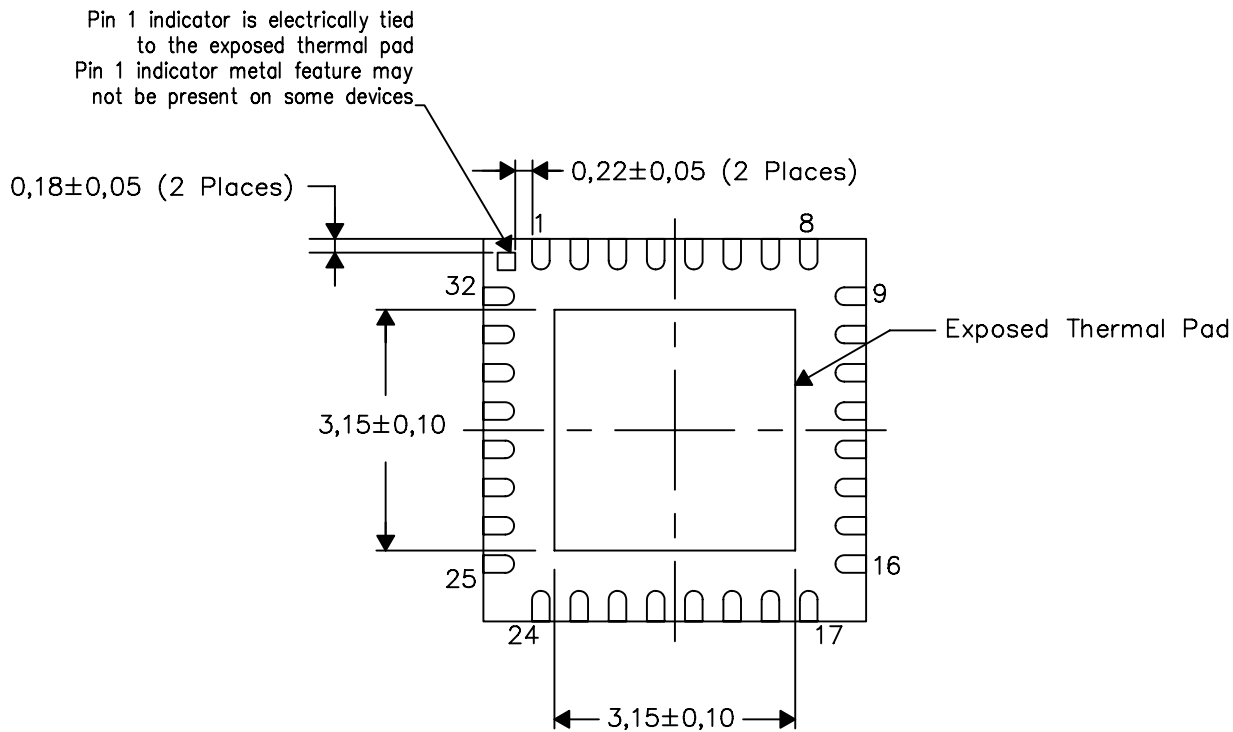

Bottom View

NOTE: All linear dimensions are in millimeters

Exposed Thermal Pad Dimensions

RHB (S-PQFP-N32)

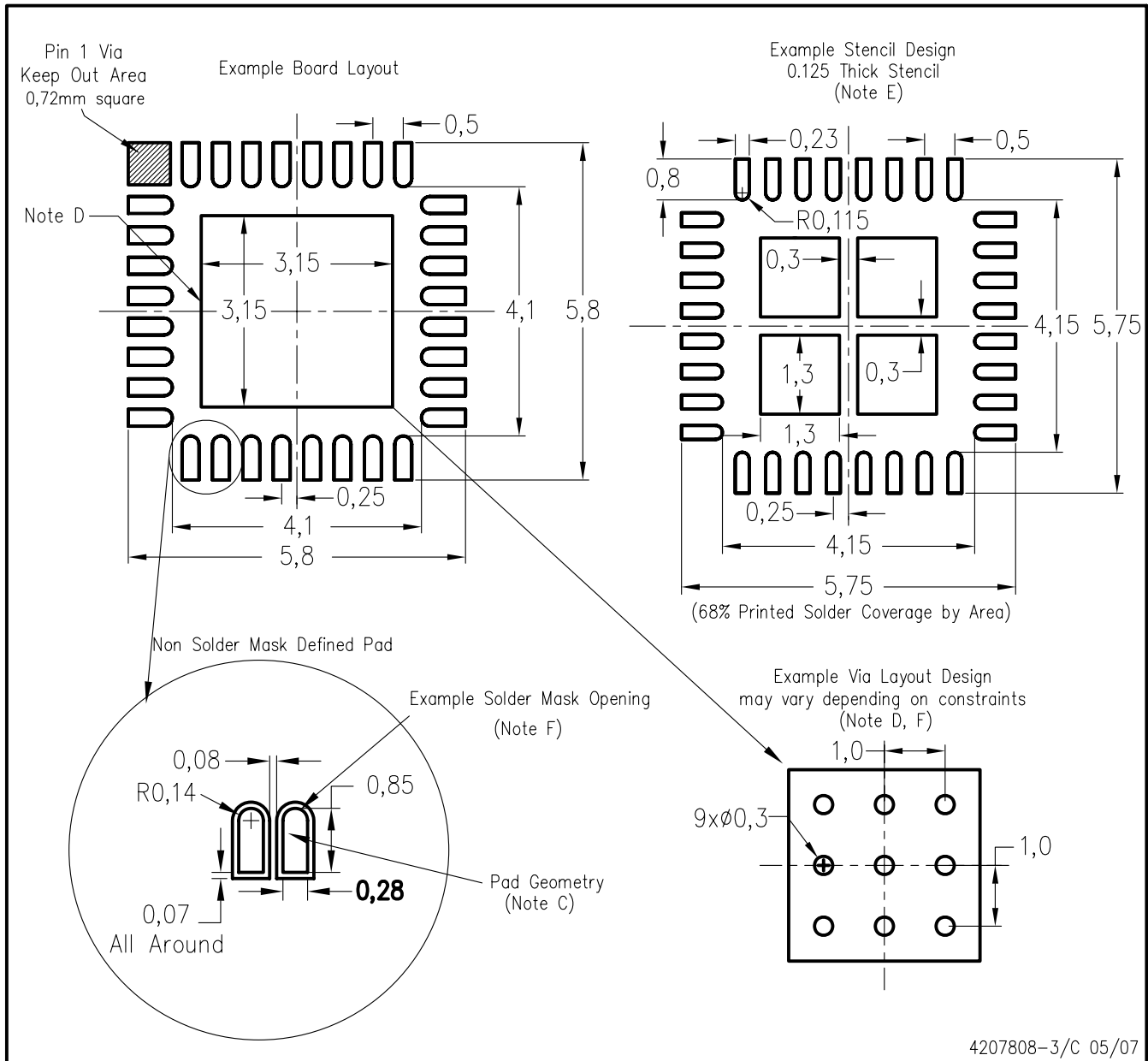

- NOTES:
- A. All linear dimensions are in millimeters.
  - B. This drawing is subject to change without notice.
  - C. Publication IPC-7351 is recommended for alternate designs.
  - D. This package is designed to be soldered to a thermal pad on the board. Refer to Application Note, Quad Flat-Pack Packages, Texas Instruments Literature No. SCBA017, SLUA271, and also the Product Data Sheets for specific thermal information, via requirements, and recommended board layout. These documents are available at [www.ti.com](http://www.ti.com) <<http://www.ti.com>>.
  - E. Laser cutting apertures with trapezoidal walls and also rounding corners will offer better paste release. Customers should contact their board assembly site for stencil design recommendations. Refer to IPC 7525 for stencil design considerations.
  - F. Customers should contact their board fabrication site for recommended solder mask tolerances and via tenting recommendations for vias placed in the thermal pad.

## IMPORTANT NOTICE

Texas Instruments Incorporated and its subsidiaries (TI) reserve the right to make corrections, modifications, enhancements, improvements, and other changes to its products and services at any time and to discontinue any product or service without notice. Customers should obtain the latest relevant information before placing orders and should verify that such information is current and complete. All products are sold subject to TI's terms and conditions of sale supplied at the time of order acknowledgment.

TI warrants performance of its hardware products to the specifications applicable at the time of sale in accordance with TI's standard warranty. Testing and other quality control techniques are used to the extent TI deems necessary to support this warranty. Except where mandated by government requirements, testing of all parameters of each product is not necessarily performed.

TI assumes no liability for applications assistance or customer product design. Customers are responsible for their products and applications using TI components. To minimize the risks associated with customer products and applications, customers should provide adequate design and operating safeguards.

TI does not warrant or represent that any license, either express or implied, is granted under any TI patent right, copyright, mask work right, or other TI intellectual property right relating to any combination, machine, or process in which TI products or services are used. Information published by TI regarding third-party products or services does not constitute a license from TI to use such products or services or a warranty or endorsement thereof. Use of such information may require a license from a third party under the patents or other intellectual property of the third party, or a license from TI under the patents or other intellectual property of TI.

Reproduction of TI information in TI data books or data sheets is permissible only if reproduction is without alteration and is accompanied by all associated warranties, conditions, limitations, and notices. Reproduction of this information with alteration is an unfair and deceptive business practice. TI is not responsible or liable for such altered documentation. Information of third parties may be subject to additional restrictions.

Resale of TI products or services with statements different from or beyond the parameters stated by TI for that product or service voids all express and any implied warranties for the associated TI product or service and is an unfair and deceptive business practice. TI is not responsible or liable for any such statements.

TI products are not authorized for use in safety-critical applications (such as life support) where a failure of the TI product would reasonably be expected to cause severe personal injury or death, unless officers of the parties have executed an agreement specifically governing such use. Buyers represent that they have all necessary expertise in the safety and regulatory ramifications of their applications, and acknowledge and agree that they are solely responsible for all legal, regulatory and safety-related requirements concerning their products and any use of TI products in such safety-critical applications, notwithstanding any applications-related information or support that may be provided by TI. Further, Buyers must fully indemnify TI and its representatives against any damages arising out of the use of TI products in such safety-critical applications.

TI products are neither designed nor intended for use in military/aerospace applications or environments unless the TI products are specifically designated by TI as military-grade or "enhanced plastic." Only products designated by TI as military-grade meet military specifications. Buyers acknowledge and agree that any such use of TI products which TI has not designated as military-grade is solely at the Buyer's risk, and that they are solely responsible for compliance with all legal and regulatory requirements in connection with such use.

TI products are neither designed nor intended for use in automotive applications or environments unless the specific TI products are designated by TI as compliant with ISO/TS 16949 requirements. Buyers acknowledge and agree that, if they use any non-designated products in automotive applications, TI will not be responsible for any failure to meet such requirements.

Following are URLs where you can obtain information on other Texas Instruments products and application solutions:

### Products

Amplifiers	<a href="http://amplifier.ti.com">amplifier.ti.com</a>
Data Converters	<a href="http://dataconverter.ti.com">dataconverter.ti.com</a>
DSP	<a href="http://dsp.ti.com">dsp.ti.com</a>
Clocks and Timers	<a href="http://www.ti.com/clocks">www.ti.com/clocks</a>
Interface	<a href="http://interface.ti.com">interface.ti.com</a>
Logic	<a href="http://logic.ti.com">logic.ti.com</a>
Power Mgmt	<a href="http://power.ti.com">power.ti.com</a>
Microcontrollers	<a href="http://microcontroller.ti.com">microcontroller.ti.com</a>
RFID	<a href="http://www.ti-rfid.com">www.ti-rfid.com</a>
RF/IF and ZigBee® Solutions	<a href="http://www.ti.com/lprf">www.ti.com/lprf</a>

### Applications

Audio	<a href="http://www.ti.com/audio">www.ti.com/audio</a>
Automotive	<a href="http://www.ti.com/automotive">www.ti.com/automotive</a>
Broadband	<a href="http://www.ti.com/broadband">www.ti.com/broadband</a>
Digital Control	<a href="http://www.ti.com/digitalcontrol">www.ti.com/digitalcontrol</a>
Medical	<a href="http://www.ti.com/medical">www.ti.com/medical</a>
Military	<a href="http://www.ti.com/military">www.ti.com/military</a>
Optical Networking	<a href="http://www.ti.com/opticalnetwork">www.ti.com/opticalnetwork</a>
Security	<a href="http://www.ti.com/security">www.ti.com/security</a>
Telephony	<a href="http://www.ti.com/telephony">www.ti.com/telephony</a>
Video & Imaging	<a href="http://www.ti.com/video">www.ti.com/video</a>
Wireless	<a href="http://www.ti.com/wireless">www.ti.com/wireless</a>

Mailing Address: Texas Instruments, Post Office Box 655303, Dallas, Texas 75265  
Copyright © 2008, Texas Instruments Incorporated